

GEAR PUMP

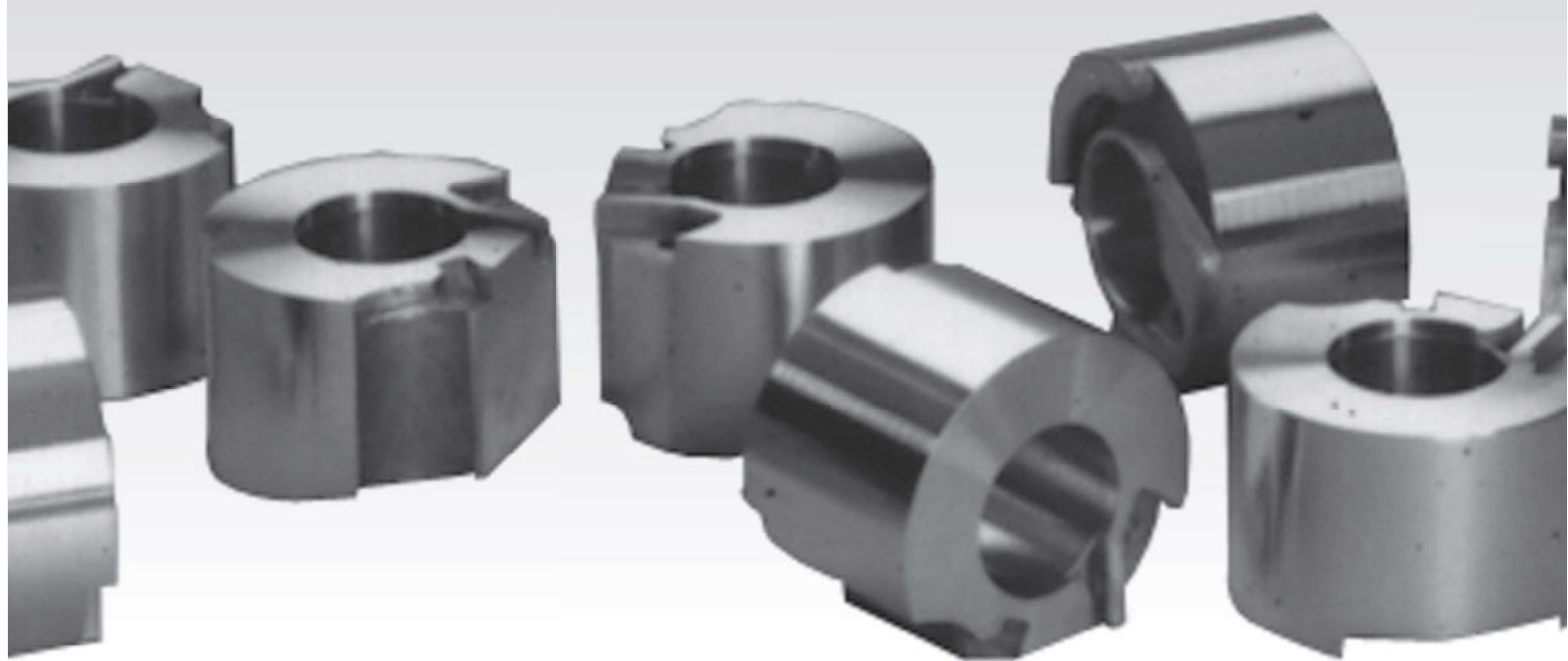

SINGLE PUMP



GROUP 0P - P3000 SERIES

PERFORMANCE DATA

Pressures quoted are relief valve maximum by-pass
Performance with SAE 20W oil at 50°C

PUMP TYPE	DISPLACEMENT	DELIVERY @1500 RPM & PRESSURE P		MAXIMUM CONTINUOUS PRESSURE P		SPEED AT MAXIMUM CONTINUOUS PRESSURE P	
	cc/rev	MIN lpm	MAX lpm	psi	bar	MAX	MIN
3003	1.27	1.0	1.9	3000	207	4000	700
3004	1.67	1.6	2.5	3000	207	4000	700
3006	2.2	2.3	3.3	3000	207	4000	700
3008	2.87	3.2	4.3	3000	207	4000	700
3011	3.8	4.5	5.7	3000	207	4000	700
3013	4.47	5.5	6.7	3000	207	4000	700
3015	5.13	6.4	7.7	3000	207	4000	700

TYPICAL PERFORMANCE

TYPICAL PUMP DELIVERY
Flow at Max. Pressure

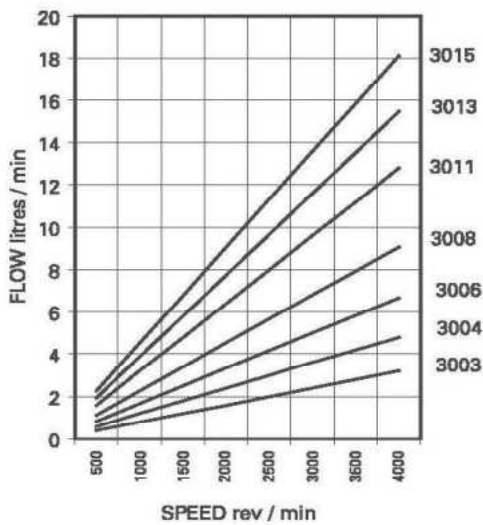

TYPICAL INPUT HORSEPOWER
Fluid SAE 20W
Fluid Temperature 50°C

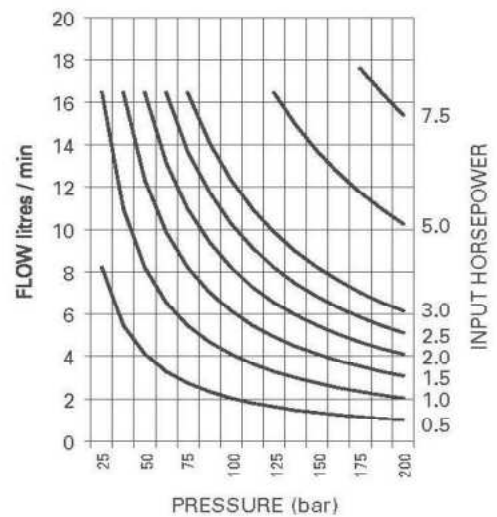

OP - PUMP SERIES

INSTALLATION DIMENSIONS - OP SERIES

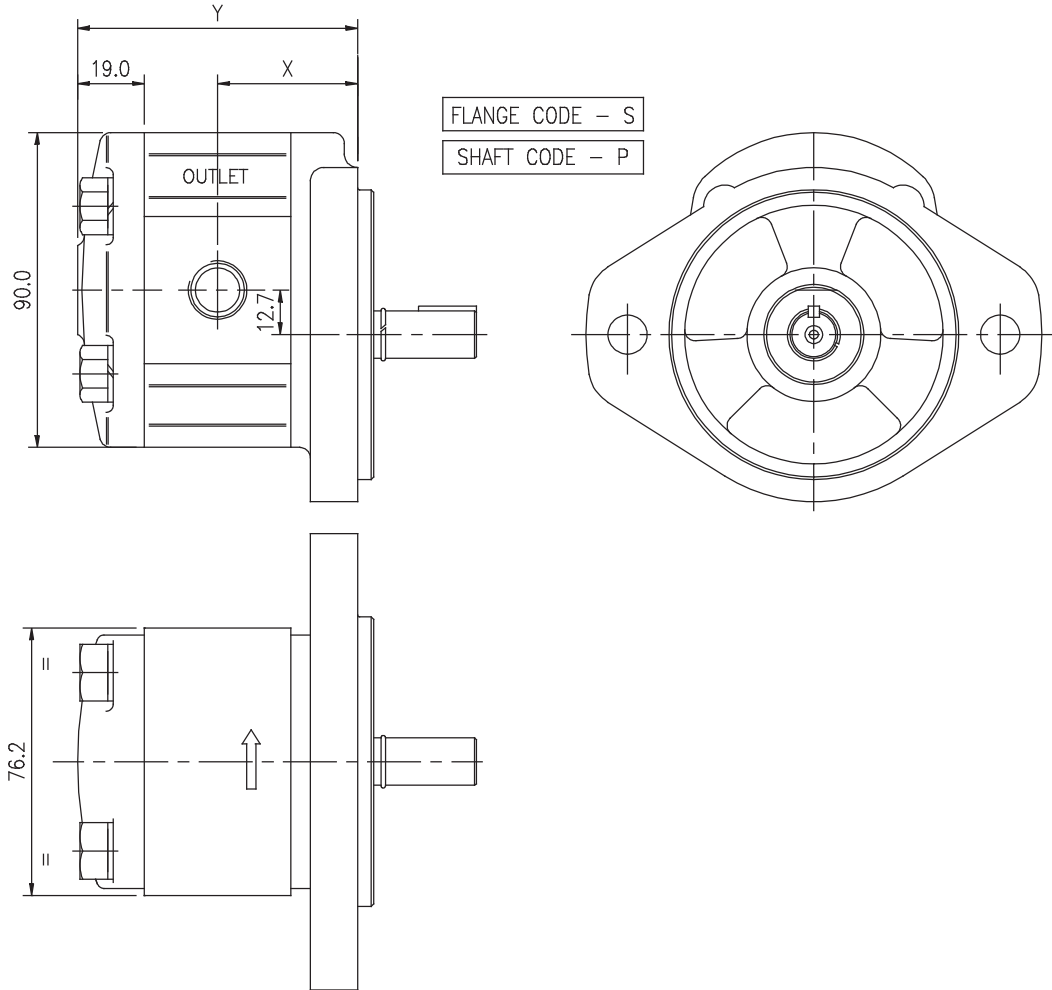

PUMP TYPE	DIMENSIONS	
	X	Y
OP-3003	38.1	76.3
OP-3004	38.6	77.1
OP-3006	39.1	78.2
OP-3008	39.9	79.7
OP-3011	40.9	81.7
OP-3013	41.5	83.1
OP-3015	42.3	84.5

NOTE:

- The representation for the pump assembly drawing is for clockwise direction of shaft rotation as viewed from pump drive shaft end. For anti-clockwise rotation of pump shaft, the position of inlet & outlet ports will interchange.
- Unless otherwise specified, the dimension 'X' is identical for both inlet & outlet port positions

ALL DIMENSIONS ARE IN mm UNLESS OTHERWISE SPECIFIED

OP - PUMP SERIES

DRIVE SHAFT CODE - L FLANGE CODE - S

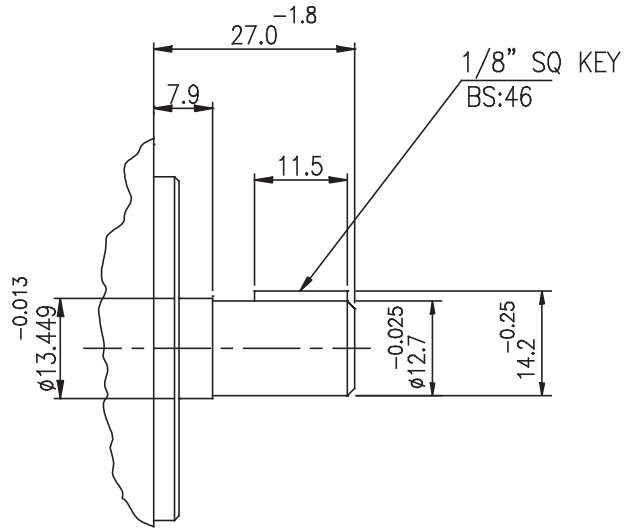

DRIVE SHAFT CODE - L FLANGE CODE - D

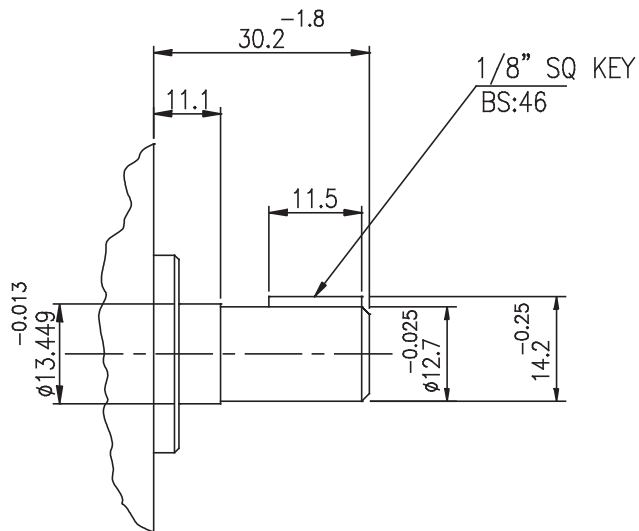

ALL DIMENSIONS ARE IN mm UNLESS OTHERWISE SPECIFIED

DRIVE SHAFT CODE - T FLANGE CODE - S

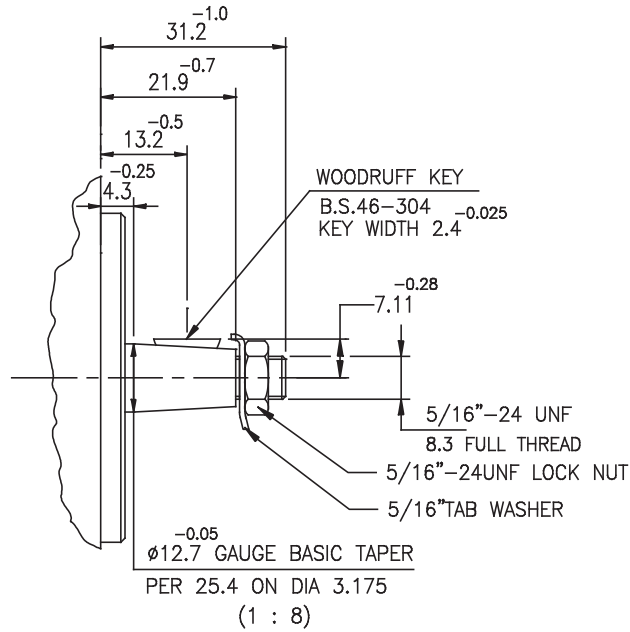

DRIVE SHAFT CODE - T FLANGE CODE - D

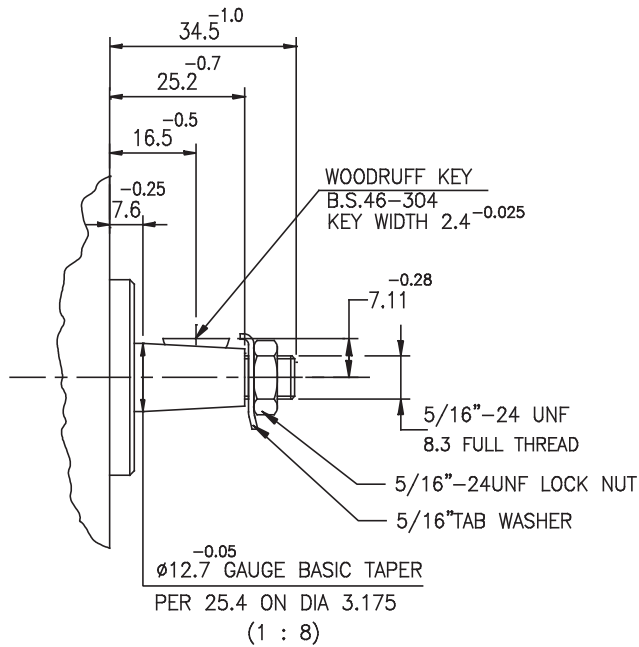

ALL DIMENSIONS ARE IN mm UNLESS OTHERWISE SPECIFIED

OP - PUMP SERIES

DRIVE SHAFT CODE - U FLANGE CODE - S

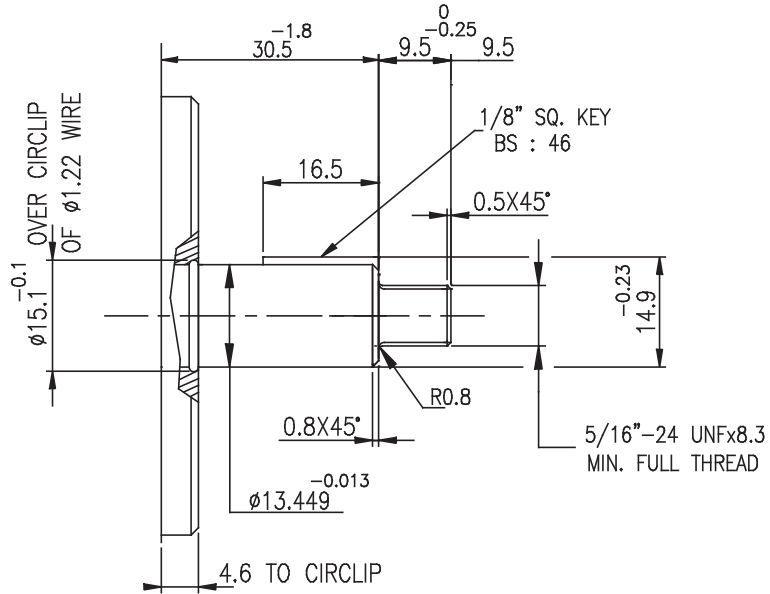

DRIVE SHAFT CODE - U FLANGE CODE - D

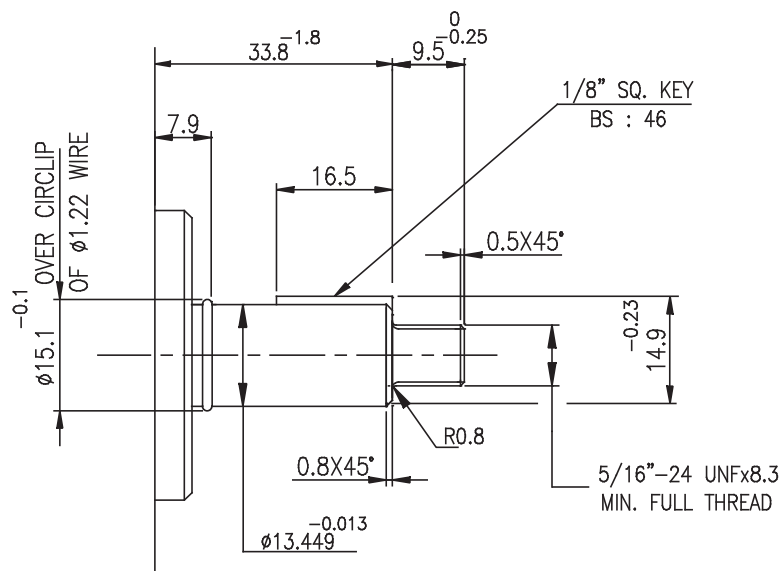

ALL DIMENSIONS ARE IN mm UNLESS OTHERWISE SPECIFIED

OP - PUMP SERIES

DRIVE SHAFT CODE - P FLANGE CODE - S

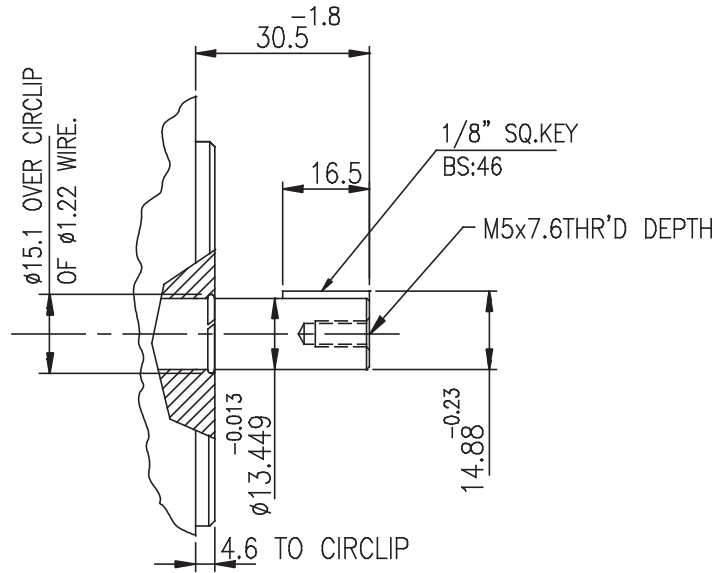

DRIVE SHAFT CODE - P FLANGE CODE - D

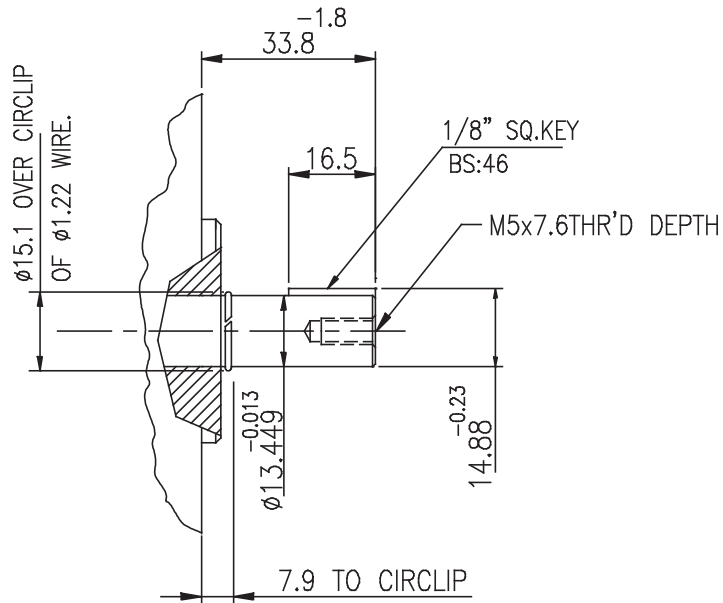

ALL DIMENSIONS ARE IN mm UNLESS OTHERWISE SPECIFIED

OP - PUMP SERIES

MOUNTING FLANGE CODE - S

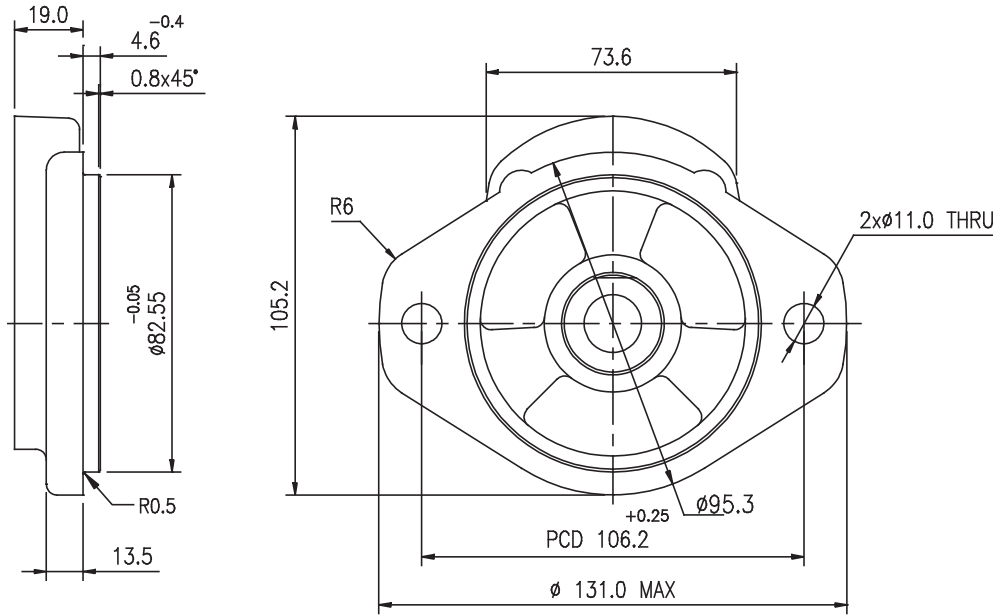

MOUNTING FLANGE CODE - D

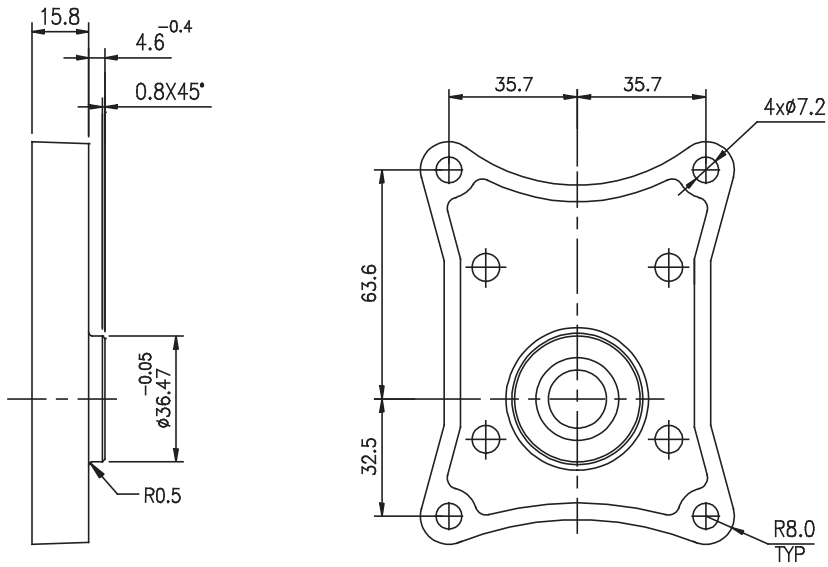

ALL DIMENSIONS ARE IN mm UNLESS OTHERWISE SPECIFIED

OP - PUMP SERIES

MOUNTING FLANGE CODE - W (WHITE INC.)

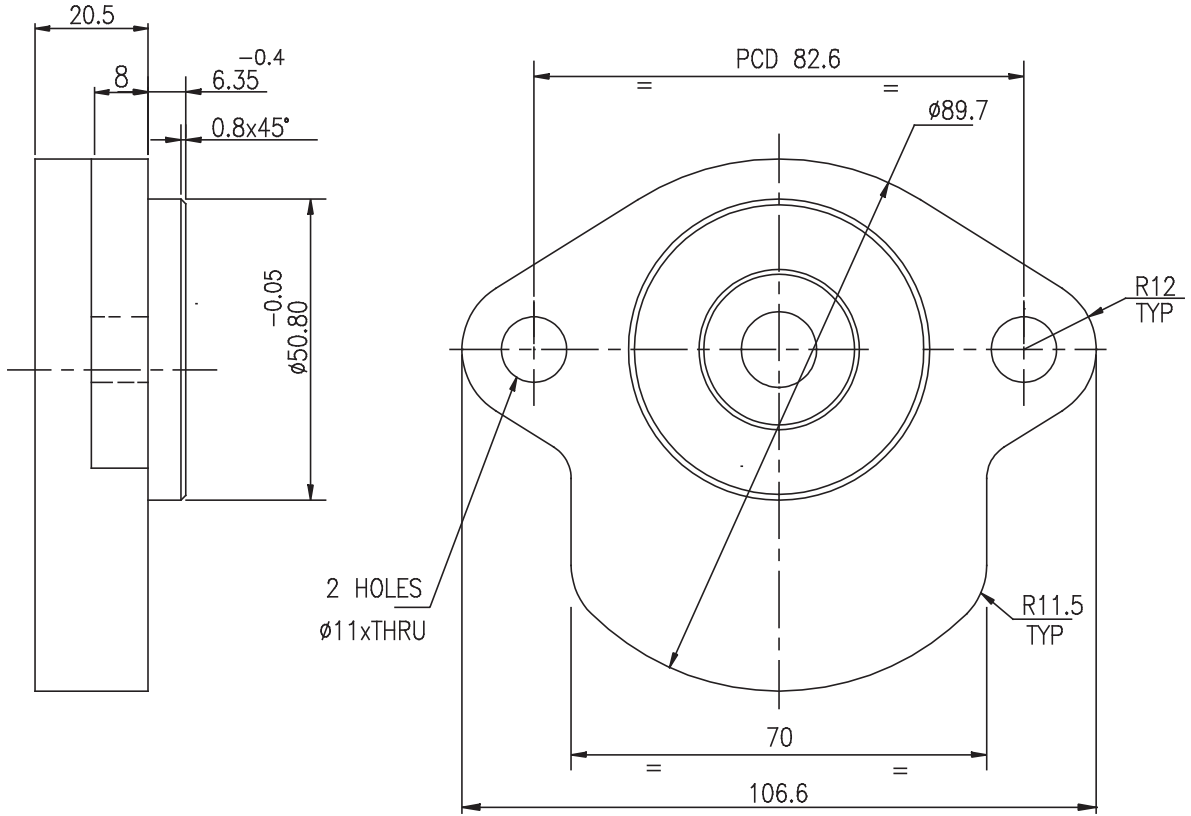

ALL DIMENSIONS ARE IN mm UNLESS OTHERWISE SPECIFIED

OP - PUMP SERIES

BODY PORT CODE - T

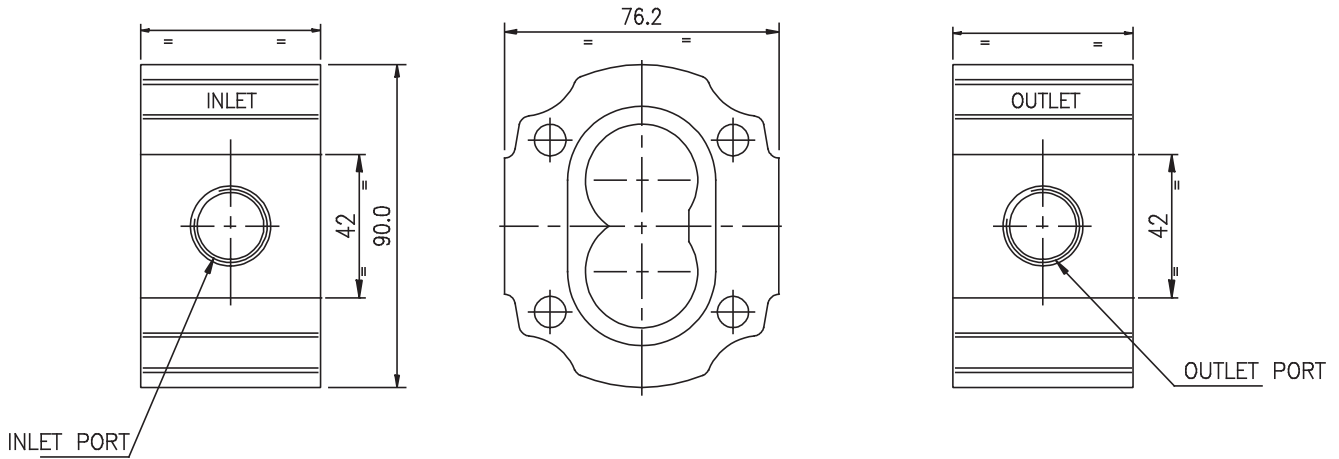

PUMP TYPE.	INLET PORT	THREAD DEPTH	OUTLET PORT	THREAD DEPTH
OP-3003	3/8" BSPF	11.4	3/8" BSPF	11.4
OP-3004	3/8" BSPF	11.4	3/8" BSPF	11.4
OP-3006	3/8" BSPF	11.4	3/8" BSPF	11.4
OP-3008	3/8" BSPF	11.4	3/8" BSPF	11.4
OP-3011	3/8" BSPF	11.4	3/8" BSPF	11.4
OP-3013	1/2" BSPF	14	1/2" BSPF	14
OP-3015	1/2" BSPF	14	1/2" BSPF	14

BODY PORT CODE - F

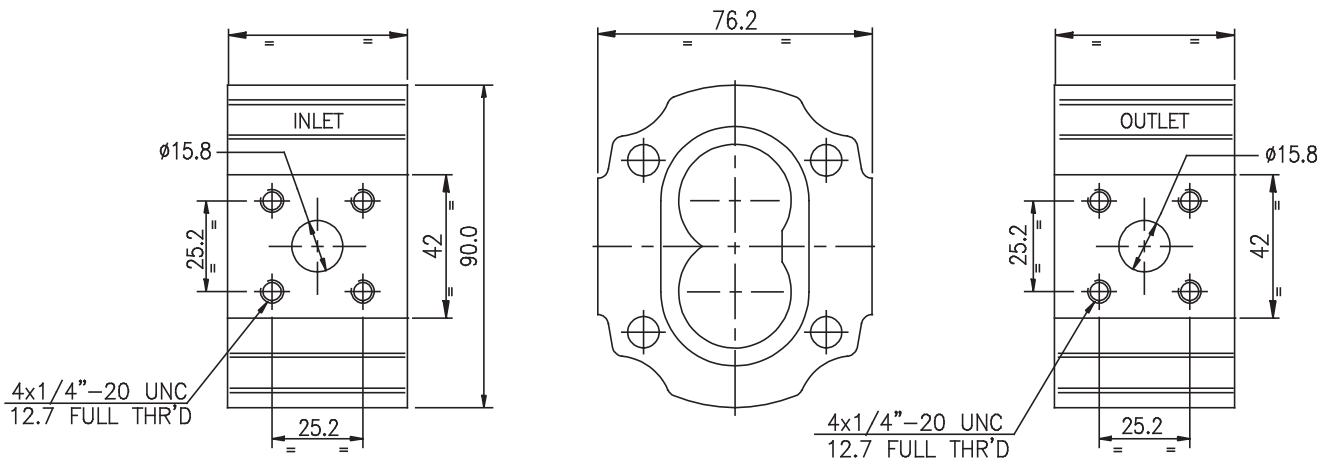

ALL DIMENSIONS ARE IN mm UNLESS OTHERWISE SPECIFIED

OP - PUMP SERIES

BODY PORT CODE - J SAE O-RING THREADED PORTS (SAE:JI926/1)

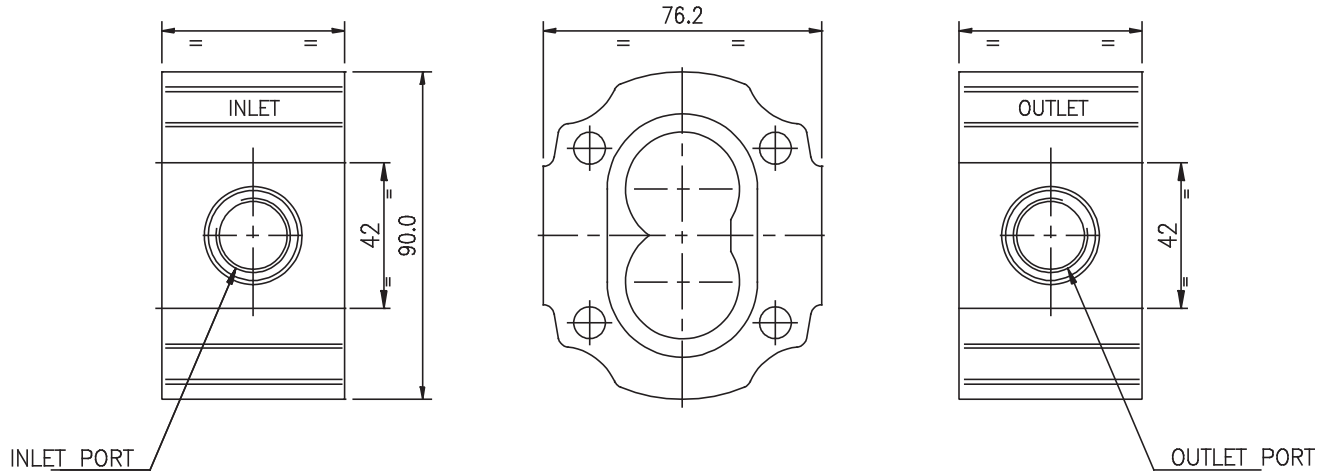

PUMP TYPE.	INLET PORT	THREAD DEPTH	OUTLET PORT	THREAD DEPTH
OP-3003	3/4"-16UN	14.2	3/4"-16UN	14.2
OP-3004	3/4"-16UN	14.2	3/4"-16UN	14.2
OP-3006	3/4"-16UN	14.2	3/4"-16UN	14.2
OP-3008	3/4"-16UN	14.2	3/4"-16UN	14.2
OP-3011	3/4"-16UN	14.2	3/4"-16UN	14.2
OP-3013	3/4"-16UN	14.2	3/4"-16UN	14.2
OP-3015	7/8"-14UN	16.5	3/4"-16UN	14.2

ALL DIMENSIONS ARE IN mm UNLESS OTHERWISE SPECIFIED

OP - PUMP SERIES

MOUNTING COVER CODE - A

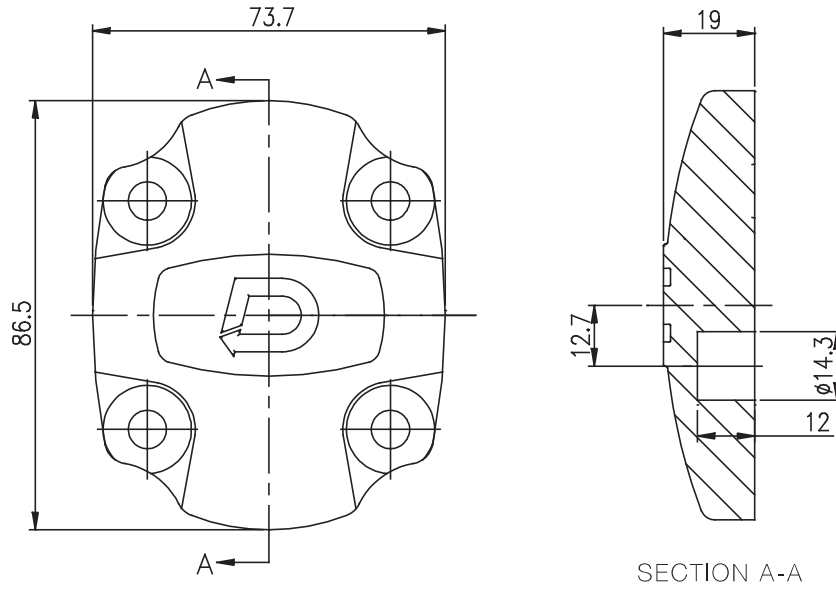

MOUNTING COVER CODE - B

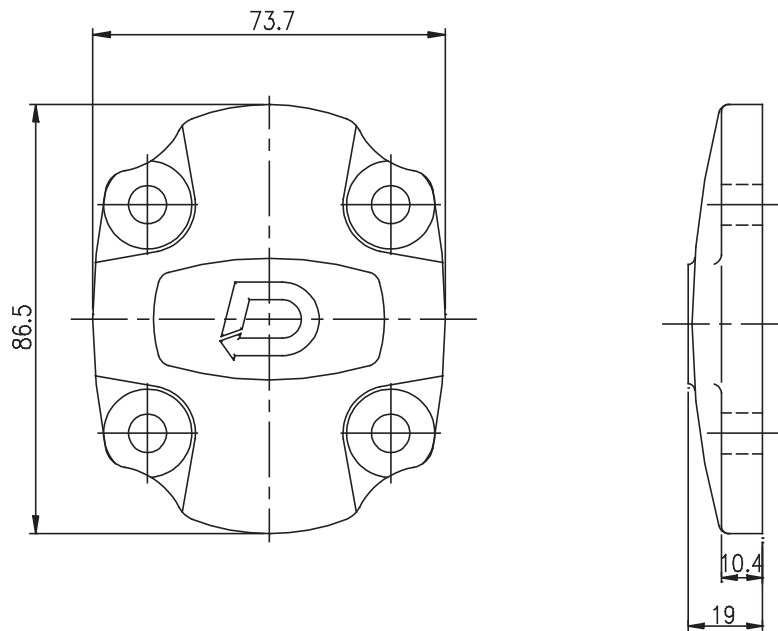

ALL DIMENSIONS ARE IN mm UNLESS OTHERWISE SPECIFIED

OP - PUMP SERIES

COVER WITH RELIEF VALVE CODE - R

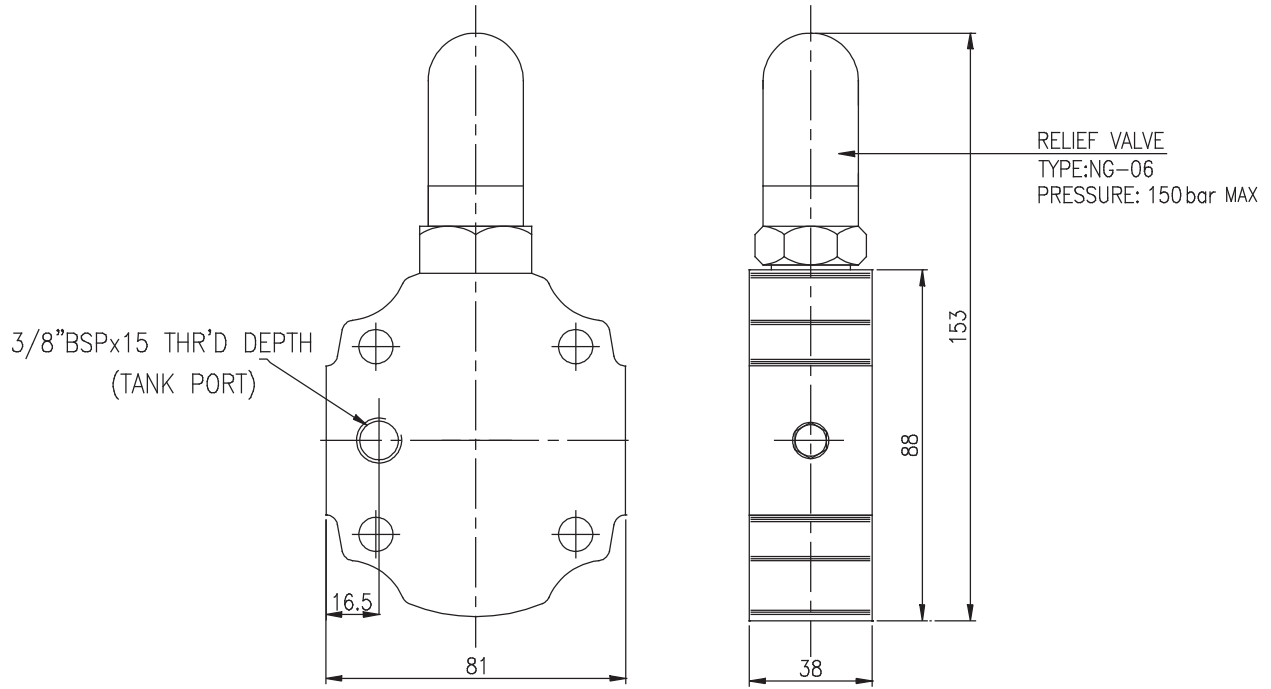

ALL DIMENSIONS ARE IN mm UNLESS OTHERWISE SPECIFIED