

Deceleration Valves
Deceleration and Check Valves

These valves are available either with or without an integral check valve which allows free reverse flow. Flow rate through the valve is regulated by the movement of the spool, which is operated by a cam. When the spool is depressed, the flow is decreased in Normally Open type valves and increased in normally Closed type valves. Their principal use is to control the speed of actuators in machine tools and similar application.

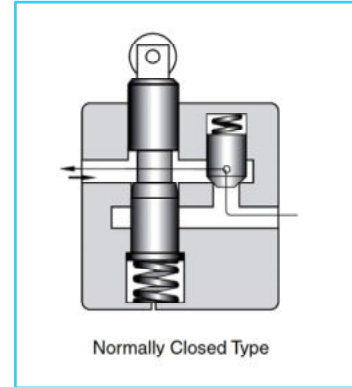
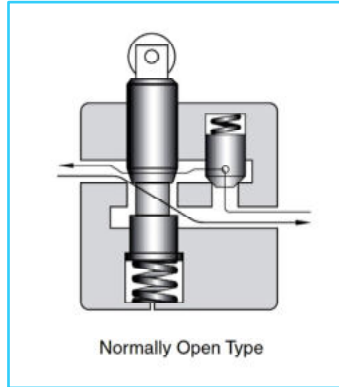

Specifications

Model Numbers	Max. Flow L/min.	Max. Operating Pressure Kg/cm ²	Mass Kg.
Z×G-03-××-22	30	210	4.3
Z×G-06-××-22	60		8.7

Model Number Designation

F-	ZC	G	-03	-T	-C	-22
Special Seals	Series Number	Type of Mounting	Valves Size	With Adjustable Needle Valve for By-Pass Line	Spool Type	Design Number
F: Special Seals for Phosphate Ester Type Fluids. (Omit if not required)	Z: Deceleration Valve ZC: Deceleration and Check Valve	G: Sub-Plate Mounting	03 06	T: With Adjustable Needle Valve (Omit if not Required)	None: Normally Open Type C: Normally Closed Type	22

Graphic Symbol

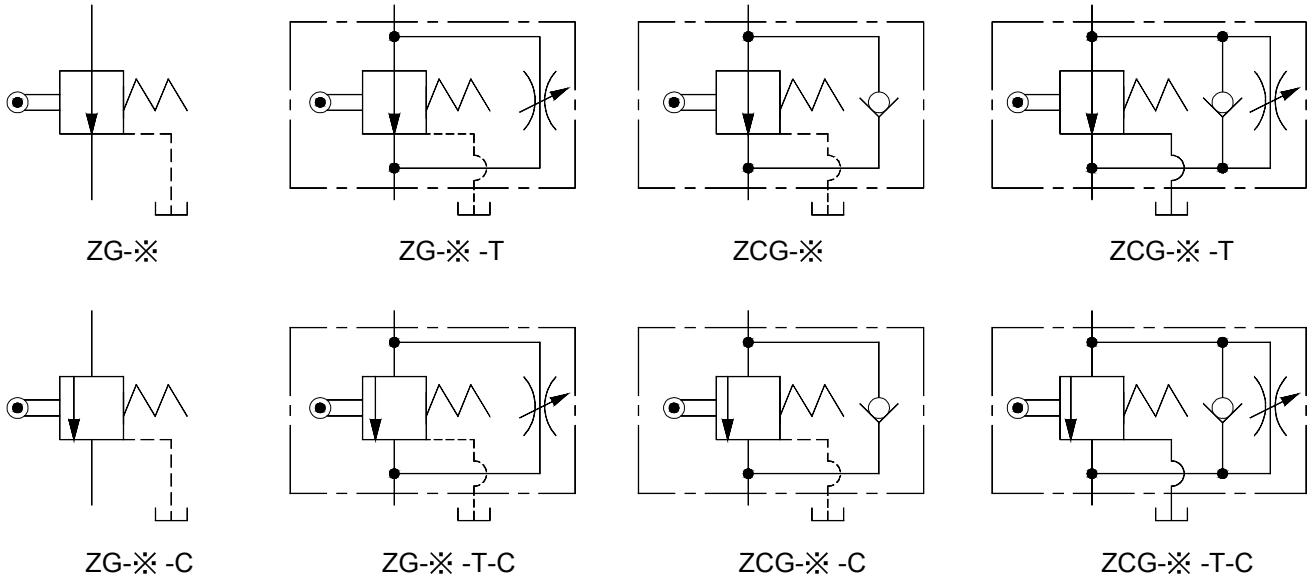

Instruction

Force to Depress Spool

Model No.	Force Kgf.
Z※G-03	15
Z※G-06	27

Drain Port Back Pressure

Limit the drain port back pressure to 1 Kgf/cm² in addition, connect the drain pipe independently and directly to the tank.

Total Leakage

cm³/min [Viscosity : 20cSt]

Model No.	Pressure Kgf/cm ²				
	10	20	50	100	210
Z※G-03	9	18	44	88	185
Z※G-06	9	17	43	86	180

Attachment

Mounting Bolts

Valve Model Numbers	Socket Head Cap Screw	Qty	Bolt Kit Model No.
Z※G-03	M8 x 75 Lg.	4	BKZG-03-20
Z※G-06	M10 x 100 Lg.	4	BKZG-06-20

Options

Bypass throttle valves

To allow a metered flow between ports even when the flow is stopped by the spool.

Sub-Plate

Valve Model Numbers	Sub-Plate Model No.	Thread Size	Mass Kg.
Z※G-03	ZGM-03-2180	3/8 BSP.F	2
Z※G-06	ZGM-06-2180	3/4 BSP.F	3.8

- Sub-plates are available. Specify sub-plate model from the table above. When sub-plates are not used, the mounting surface should have good machined finish.

Metered Flow Vs. Spool Depression

Z※G-03

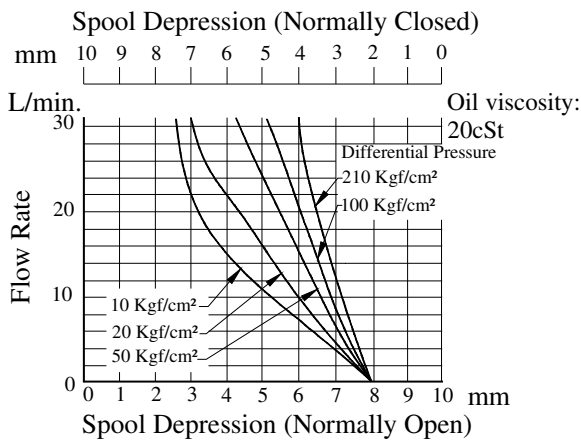

Metered Flow for Needle Valve

Z※G-03-T

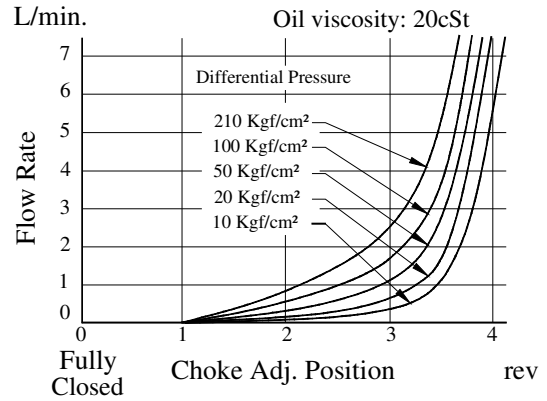

Z※G-06

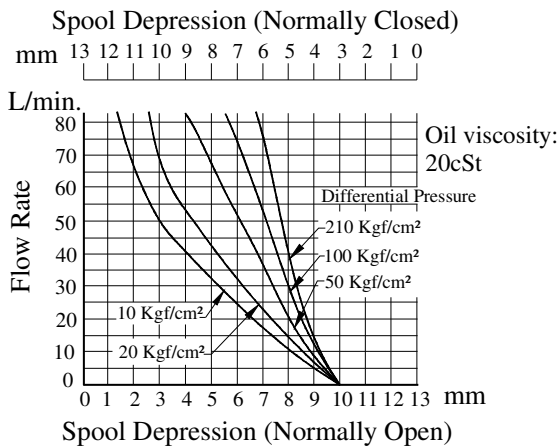

Z※G-06-T

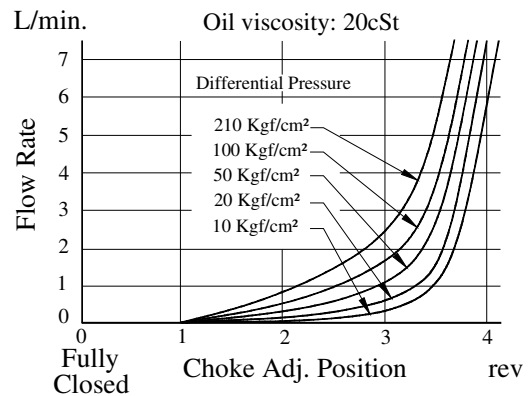

Pressure Drop for Reversed Free Flow

Z※G-03

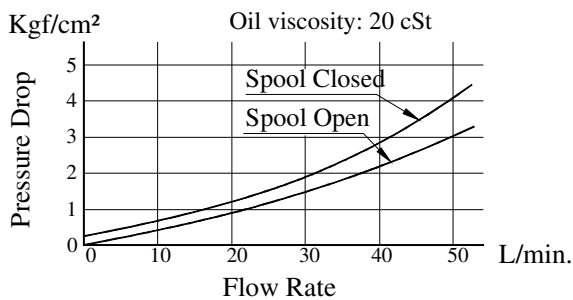

Z※G-06

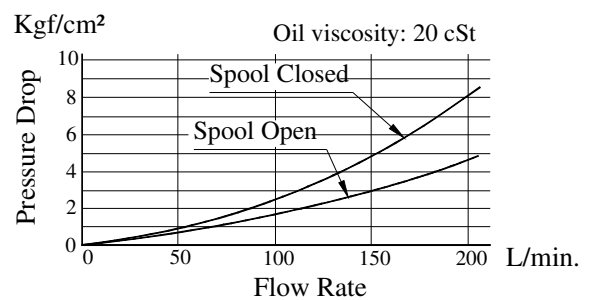

● **ZG - 03 - ※ - ※ - 22**
ZCG - 06

Model numbers	Port "A"	Port "B"
ZG-※-	Controlled Flow inlet	Controlled Flow outlet
ZCG-※-	Controlled Flow inlet or Reversed free flow outlet	Controlled Flow outlet or Reversed free flow inlet

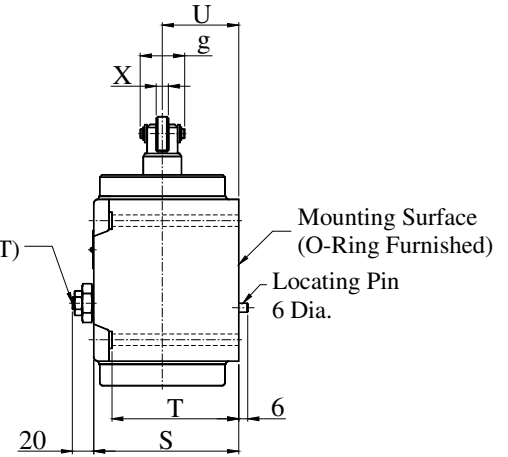
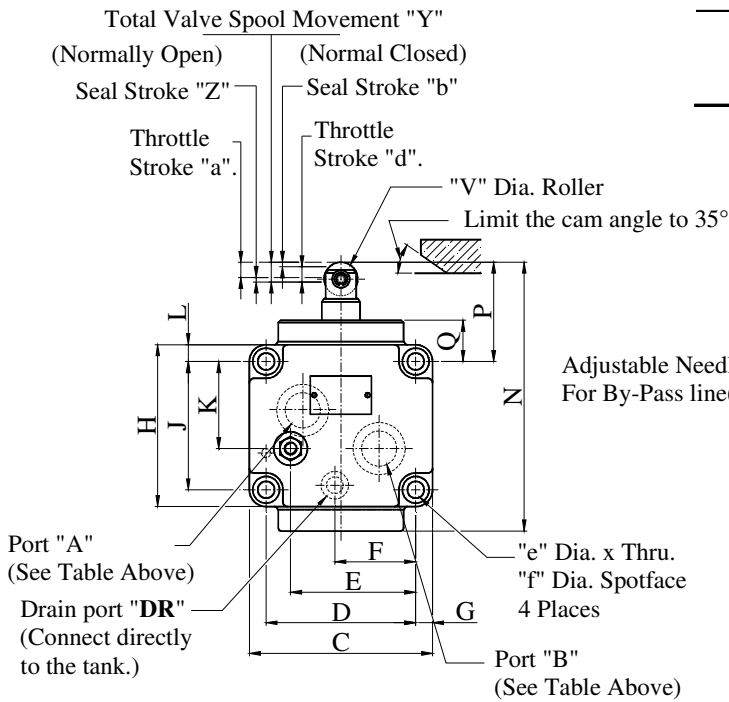

Model Number	C	D	E	F	G	H	J	K	L	N	P	Q	S
Z※G-03	102	80	66	40	11	82	60	41	11	141	56	25	70
Z※G-06	120	98	82	49	11	106	84	57	11	176	65	27	95

Model Number	T	U	V	X	Y	Z	a	b	d	e	f	g
Z※G-03	60	35	18	6	10	2	8	2	8	8.8	14	24.5
Z※G-06	85	50	22	8	13	3	10	3	10	11	17.5	29

● **Sub-Plate: ZGM-03,06**

DIMENSIONS IN MILLIMETRES

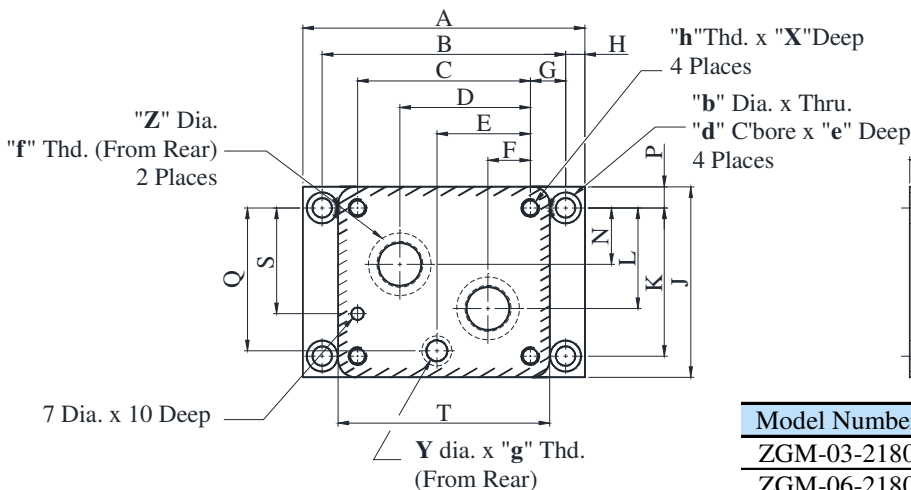

Model Number	"f" Thd.	"g" Thd.	"h" Thd.
ZGM-03-2180	3/8 BSP.F	1/4 BSP.F	M8
ZGM-06-2180	3/4 BSP.F	1/4 BSP.F	M10

Model Number	A	B	C	D	E	F	G	H	J	K
Z※G-03	146	124	80	60	42	20	22	11	85	60
Z※G-06	160	138	98	74	53	24	20	11	108	84

Model Number	L	N	P	Q	S	T	U	X	Y	Z	b	d	e
Z※G-03	40	20	12.5	58	44	102	26	18	6.2	15	11	17.5	10.8
Z※G-06	57	32	12	81	60	120	35	18	11	24.5	11	17.5	10.8

■ Spare Parts List

● **List of Seals**

Sl. No.	Name of Parts	Part Numbers			
		Z※G-03	Qty	Z※G-06	Qty
1	O-Ring	SO-NB-P18	2	SO-NB-P36	2
2	O-Ring	SO-NB-P9	1	SO-NA-P25	1
3	O-Ring	SO-NB-P32	2	*SO-NB-P18	1
4	O-Ring	SO-NA-P20	1	^T SO-NA-P5	1
5	O-Ring	*SO-NB-P12	1	SO-NB-P28	2
6	O-Ring	^T SO-NA-P5	1	SO-NB-P14	1
7	Back up Ring	^T SO-BB-P5	1	^T SO-BB-P5	1

Note:

* - only applicable for ZCG-03/ZCG-06

T – Only applicable for valves with needle valve option.

When ordering the seals, please specify the seal kit number from the table below.

● **List of Seals Kits**

Model Numbers	Seal Kit Numbers	
	With Std. model	Model with “T” Option
ZG-03	KS-ZG-03-22	KS-ZG-03-T-22
ZCG-03	KS-ZCG-03-22	KS-ZCG-03-T-22
ZG-06	KS-ZG-06-22	KS-ZG-06-T-22
ZCG-06	KS-ZCG-06-22	KS-ZCG-06-T-22