

**Feed Control Valves**

These Valves are the combination of flow control valve, a deceleration valve and a check valve and used mainly for controlling rapid traverse and feed cycle in machine tools. Switching from rapid traverse to feed is made by a cam operation and fine feed control is accomplished by dial rotation regardless of pressure and oil temperature variation. Rapid return is free of cam actuation.

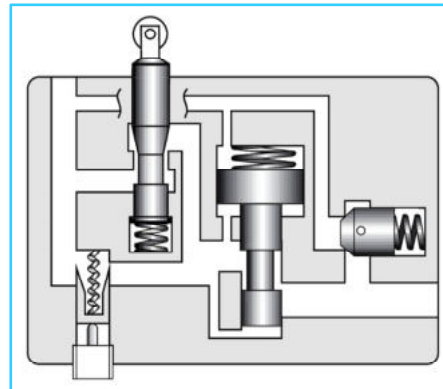

**Specifications**

Model Numbers	Max. Flow <sup>*1</sup> L/min	Metered Flow Range L/min		Max. Reversed Free Flow L/min.	Max. Operating Pressure Kgf/cm <sup>2</sup>	Approx. Mass Kg	
		Feed	Fine Feed				
UCF1G-01-4-A-11	16 [12]	0.03-4 [0.05-4] <sup>*2</sup>	---	20	140	1.6	
UCF1G-01-4-B-11	12 [8]						
UCF1G-01-4-C-11	8 [4]						
UCF1G-01-8-A-11	20 [12]	0.03-8 [0.05-8] <sup>*2</sup>	---				
UCF1G-01-8-B-11	16 [8]						
UCF1G-01-8-C-11	12 [4]						
UCF1G-03-4-10	40 [40]	0.05-4	---	40	140	2.6	
UCF1G-03-8-10		0.05-8					
UCF2G-03-4-10	40 [40]	0.1-4	0.05-4	40		140	2.7
UCF2G-03-8-10		0.1-8	0.05-4				

\* 1 The maximum flow rates are values with the deceleration valve and the flow control valve fully open. The values in [ ] are maximum flow rates with the deceleration valve fully open and the flow control valve fully closed.

\* 2 The values in [ ] are for pressure above 70 Kgf/cm<sup>2</sup>.

**Model Number Designation**

F	UCF1	G	-01	-4	-A	-E	-11
Special Seals	Series Number	Type of Mounting	Valve Size	Max. Metered Flow L/min.	Deceleration Valve Max. Flow L/min.	Drain Connection	Design Number
<b>F:</b> Special Seals for Phosphate Ester Type Fluids. (Omit if not required)	<b>UCF1:</b> Single Feed Control	<b>G:</b> Gasket Mounting	<b>01</b>	<b>4 : 4    8 : 8</b>	<b>A:12, B:8, C:4</b>	<b>None:</b> Internal Drain	<b>11</b>
			<b>03</b>	<b>4 : 4    8 : 8</b>	<b>---</b>		<b>10</b>
	<b>UCF2:</b> Double Feed Control		<b>03</b>	<b>4 : 4    8 : 8</b>	<b>---</b>		<b>E:</b> External Drain

Graphic Symbol

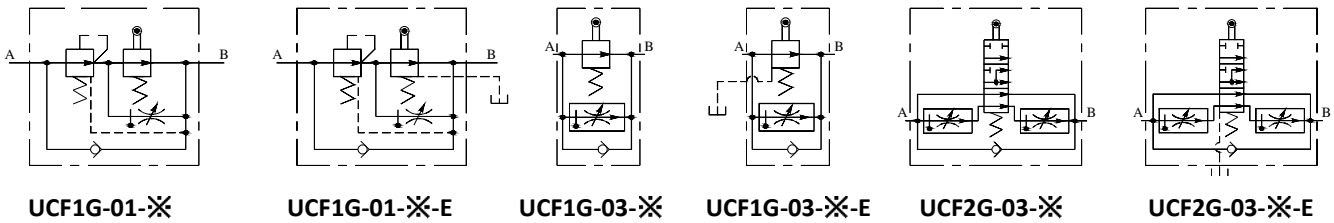

Instructions

Allowable Pressure at controlled Flow Outlet

If internal drain types of UCF1G-01 or UCF2G-03 are used, use them in metre-out circuits in order to limit the valve outlet pressure to the values shown below.

In addition, external drain types can also be used in metre-in circuits.

Model Number	Allowable outlet Back Pressure Kgf/cm <sup>2</sup>
UCF1G-01-※	3
UCF1G-03-※	
UCF2G-03-※	
UCF1G-01-※-E	140
UCF1G-03-※-E	
UCF2G-03-※-E	

Minimum required pressure difference

The minimum differential pressure between inlet and outlet port is required to obtain the optimum pressure compensation. It varies according to the flow rate to be set. For details, please refer to the performance curve.

Spool push down level

Limit the spool push down level within the allowable maximum stroke range shown in the installation drawings.

Sub-Plate

Valve Model Number	Sub-Plate Model Number	Mass Kg.
UCF1G-01-※-※-※-11	UCF1GM-01-1080	1.5
UCF1G-03-※-※-※-10	UCF1GM-03-1080	2.3
UCF2G-03-※-※-※-10	UCF2GM-03-1080	1.9

Sub-Plate are available . Specify sub-plate model from the table.

When Sub-Plates are not used, the mounting surface should have a good machined finish.

Required Force for Spool Push Down

Model Number	Drain Type	Force Kgf
UCF1G-01	Internal drain type	10
	External drain type	8
UCF1G-03	Internal drain type	17
	External drain type	9
UCF2G-03	Internal drain type	17
	External drain type	13

Note: The push down forces are with the maximum allowable pressure at the port concerned, which is controlled flow outlet “B” for internal drain types or the drain port for internal drain types.

Allowable drain port back pressure

Limit to 1 Kgf/cm<sup>2</sup>

In addition, connect the drain pipe independently and directly to the tank.

(This applies only to external drain types)

Line filter

To carry out flow adjustments by as small degree as 2 L/min or less, be sure to use a line filter, 10µm or less, near the valve inlet.

Flow adjustment

Loosen locking screw and turn flow adjustment dial clockwise for increase, anti-clockwise for decrease.

The dial makes about Four revolutions from zero to full flow and the valve opening indicated on the revolution indicator. After flow adjustment, tighten locking screw.

• UCF1G-01-※-※-※-11

DIMENSIONS IN MILLIMETRES

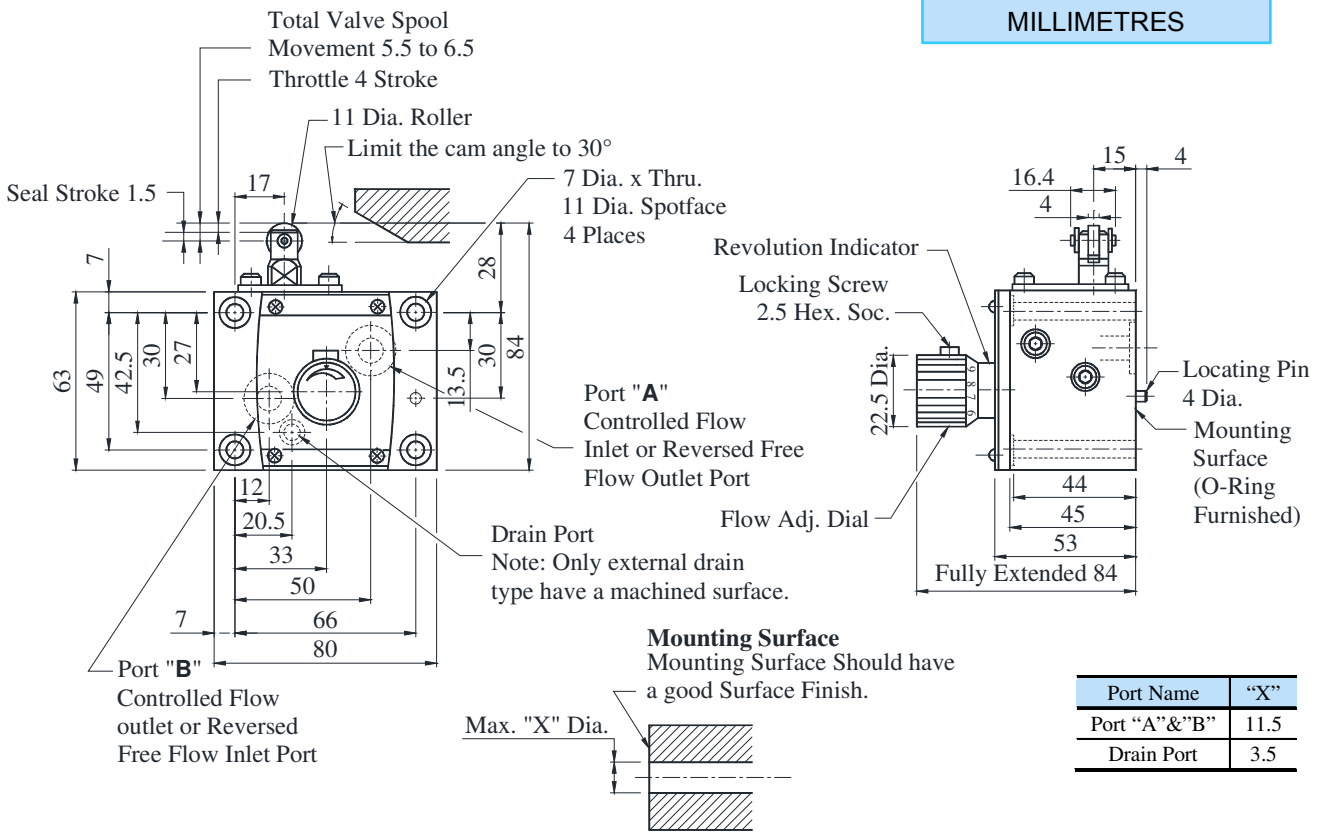

• UCF1G-03-※-※-※-10

Port Name	"X"
Port "A"&"B"	11.5
Drain Port	4

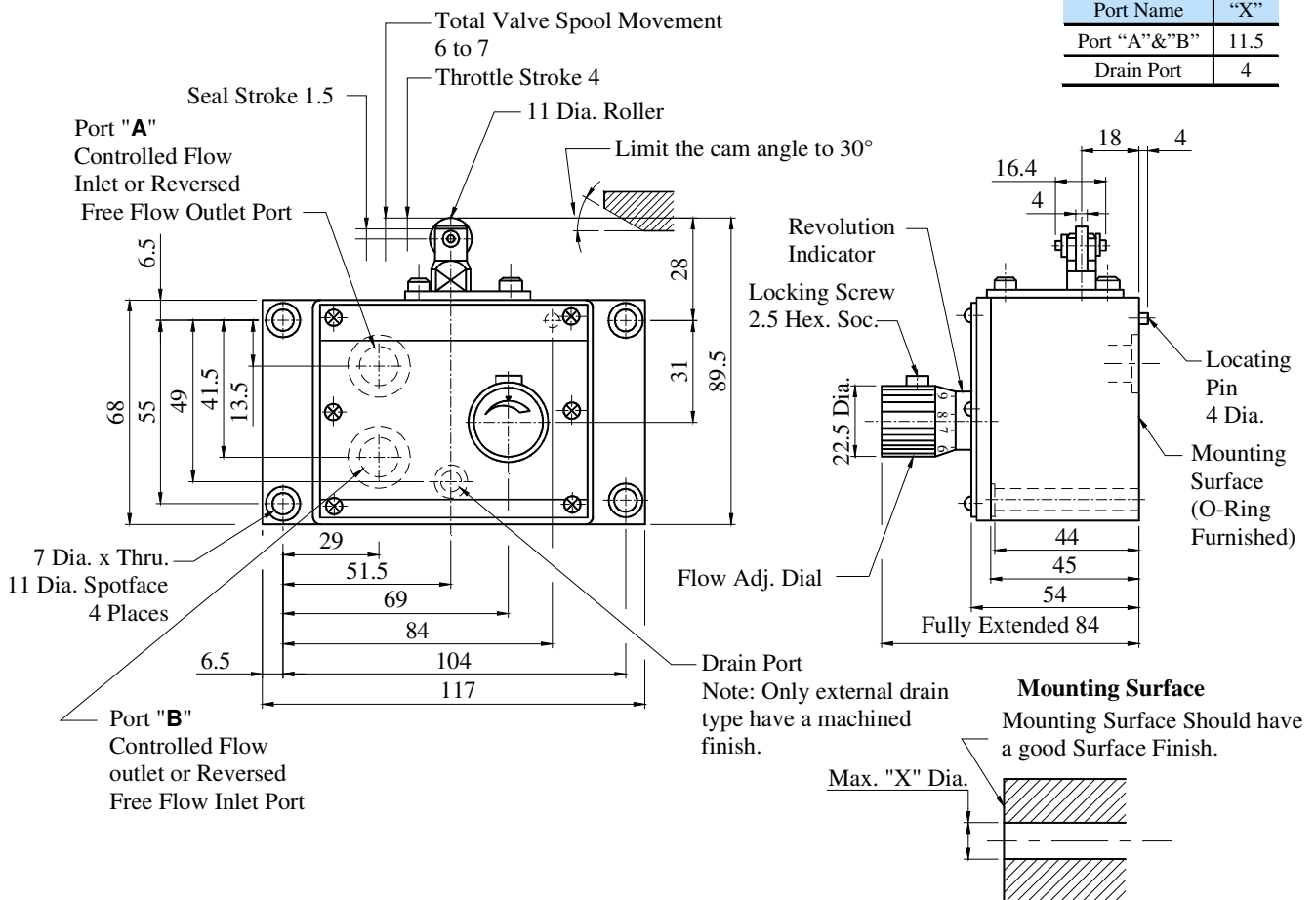

● **UCF2G-03-※-※-※-10**

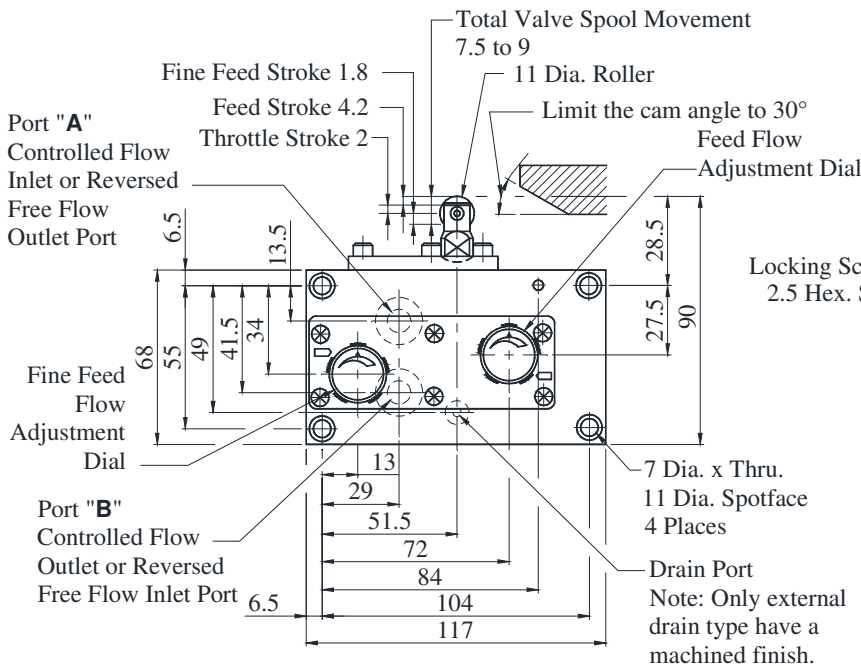

**DIMENSIONS IN MILLIMETRES**

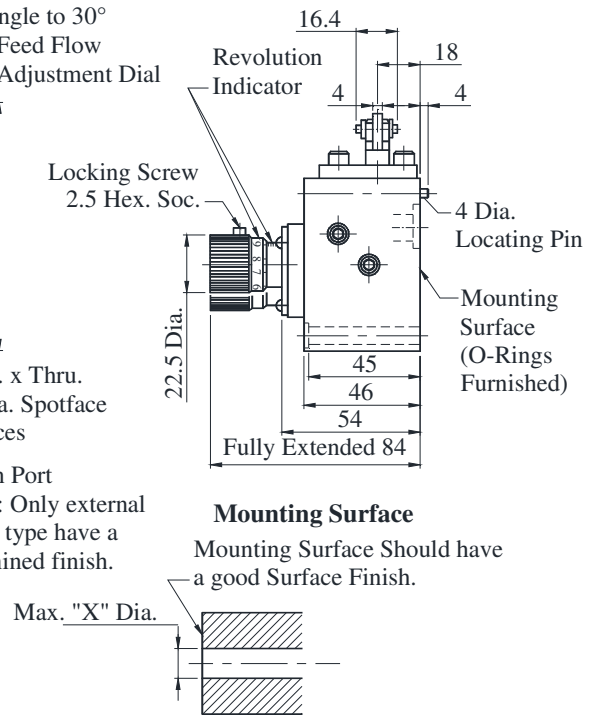

Port Name	"X"
Port "A" "B"	11.5
Drain Port	4

**Attachment**

● **Mounting Bolts**

Valve Model Numbers	Sockets Head Cap Screw.	Qty.	Bolt Kit Model No.
UCF1G-01	M6 x 55 Lg.	4	BKUCF1G-01-11
UCF1G-03	M6 x 55 Lg.	4	BKUCF1G-03-10
UCF2G-03	M6 x 55 Lg.	4	BKUCF2G-03-10

● **Sub-Plate: UCF1GM-01-※-1080**

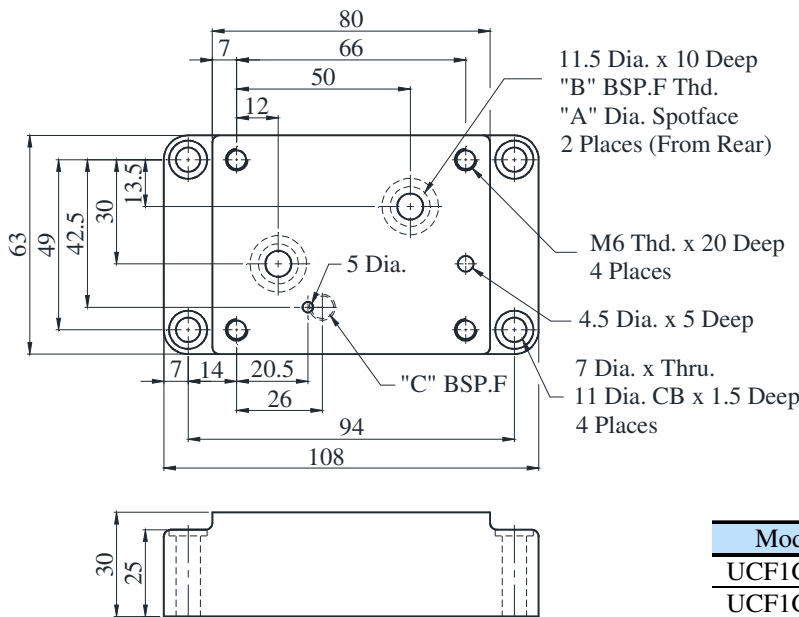

**DIMENSIONS IN MILLIMETRES**

Model Numbers	A	B	C
UCF1GM-01-1080	16.25	1/8	-
UCF1GM-01-E-1080	21	1/4	1/8

● **Sub-Plate: UCF※GM-03-※ -1080**

**DIMENSIONS IN MILLIMETRES**

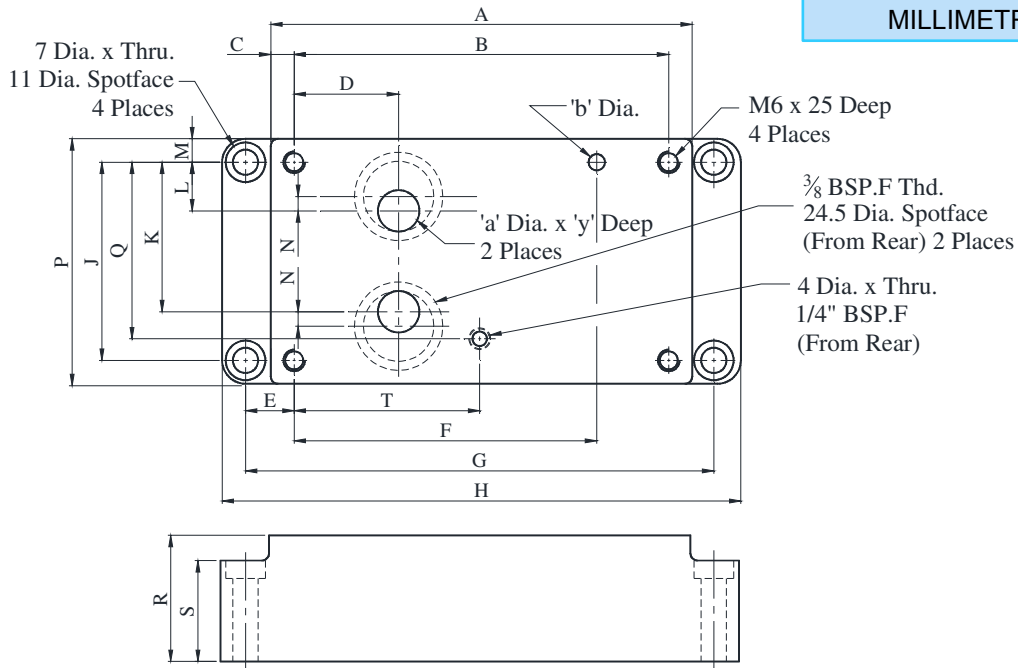

Model Numbers	A	B	C	D	E	F	G	H	J
UCF1GM-03-1080	117	104	6.5	29	13.5	84	131	144	55
UCF2GM-03-1080	117	104	6.5	29	16.5	84	137	150	55

Model Numbers	K	L	M	N	P	Q	R	S	T	“y”	“a”	“b”
UCF1GM-03-1080	41.5	13.5	6.5	4	68	49	35	28	51.5	7	11.5	4.5
UCF2GM-03-1080	41.5	13.5	6.5	5	68	49	30	22	51.5	10	11	4

■ **Min. Recommended Pressure Drop**

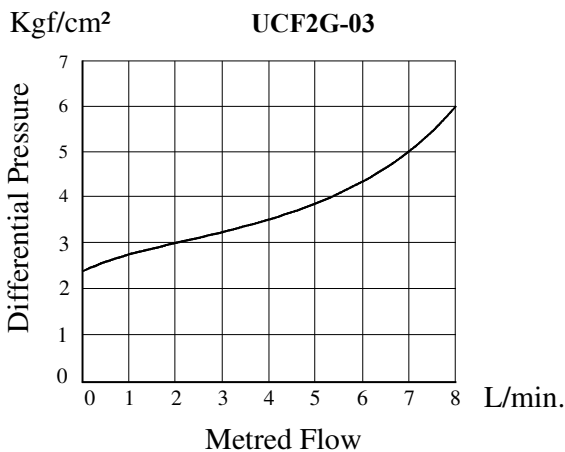
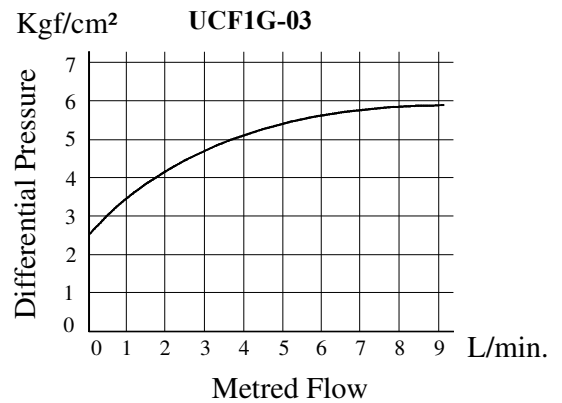
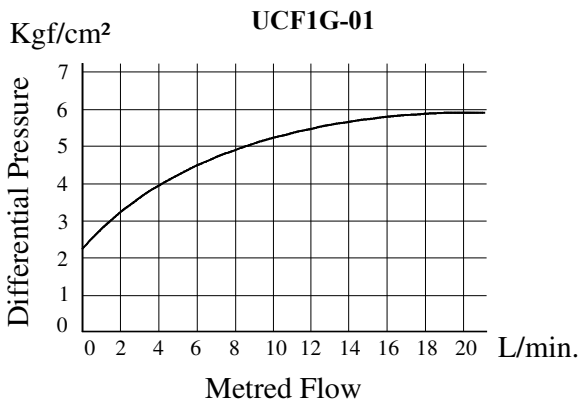

## ■ Spare Parts List

### ● List of Seals

Sl. No.	Name of Parts	Part Numbers					
		UCF1G-01	Qty.	UCF1G-03	Qty.	UCF2G-03	Qty.
1	O-Ring	SO-NA-P4	1	SO-NA-P4	1	SO-NA-P4	2
2	O-Ring	SO-NB-P7	1	SO-NB-P10	1	*1SO-NB-P6	1
3	O-Ring	SO-NA-P10	1	SO-NB-P10A	1	SO-NB-P10	2
4	O-Ring	SO-NB-P10	2	SO-NA-P12	1	SO-NB-P10A	1
5	O-Ring	SO-NB-P10A	1	SO-NB-P14	3	SO-NA-P12	1
6	O-Ring	SO-NB-P14	2	SO-NB-P16	1	SO-NB-P14	3
7	O-Ring	SO-NB-P16	1	SO-NB-P18	1	SO-NB-P16	1
8	O-Ring	*1SO-NB-P5	1	*1SO-NA-P6	1	SO-NB-P21	1
9	Back up Ring	-	-	-	-	*2SO-BB-P12	1

\*1 These seals are applicable only for external drain models.

\*2 Used only for internal drain types.

Note : When ordering the seals, please specify the seal kit number from the table below.

### ● List of Seals

Model numbers	Seal Kit Numbers
UCF1G-01	KS-UCF1G-01-11
UCF1G-03	KS-UCF1G-03-10
UCF2G-03	KS-UCF2G-03-10