

Pressure Switches

- Pressure switches are used to make or break an electrical circuit at a preset hydraulic pressure.
- The Pressure switch has two microswitches, each of which is capable of electrically detecting high pressure or low pressure setting. The microswitch structure is dust and drip proof structure.



Specifications

Model number	Max. operating Pressure Kgf/cm ²	Mass Kg.
Sub-Plate Mounting		
SG-02-※-2080	350	4.5

Micro Switch Ratings

Loads	AC		DC
	Normally Closed Contact	Normally Open Contact	
Inductive Load			0.05A – 125V 0.03A – 250V
Electric Motor Incandescent Lamp Electromagnetic Coil Load	4.5A – 125V 3.0A – 250V	2.5A – 125V 1.5A – 250V	-----

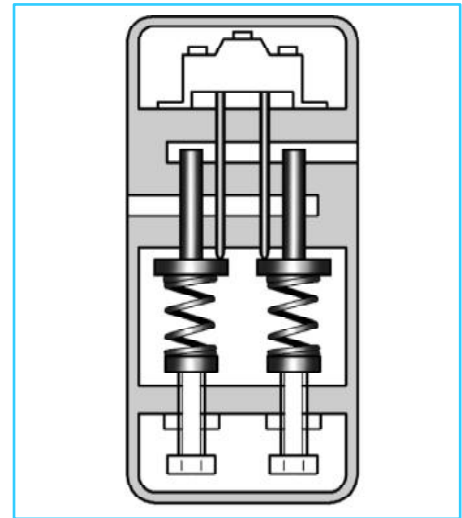

Graphic Symbol



Model Number Designation

F-	S	G	-02	-B	-20	80
Special Seals	Series number	Type of Mounting	Valve Size	Pres. Adj. Range Kgf/cm ²	Design Number	Design Standard
F: Special Seals for Phosphate Ester Type Fluids. (Omit if not required)	S: Pressure Switches	G: Sub-Plate mounting	02	B: 7-70 C: 35-140 H: 70-210 K: 105-350	20	80

Instructions

Pressure Adjustments

Remove the front cover and loosen the lock nut. Turn the pressure adjustment screw slowly clockwise for higher pressure or anti-clockwise for lower pressures. After adjustments, be sure to tighten the lock nut and replace the front cover in position.

Drain piping

Connect the drain pipe not to any other line but directly to the tank.

Attachment

Mounting Bolts

Valve Model Number	Socket Head cap Screw	Qty.	Bolt Kit Ordering Code
SG-02-2080	M6 x 60 Lg.	2	BKSG-02-20

Sub-plate

Valve Model Number	Sub-Plate Model Number	Thread Size	Mass Kg.
SG-02	SGM-02-2080	1/4 BSP.F	1.1

Sub-plates are available. Specify sub-plate model from the table above. When sub-plates are not used, the mounting surface should have a good machined finish.

Pressures and microswitch contacts

Pressure	Contact point	
	High pressure Microswitch	Low Pressure Microswitch
Under the Setting Pressure		
Above the Setting Pressure		

Microswitch terminals

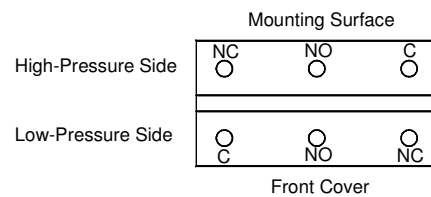

SG-02-※-2080

DIMENSIONS IN MILLIMETRES

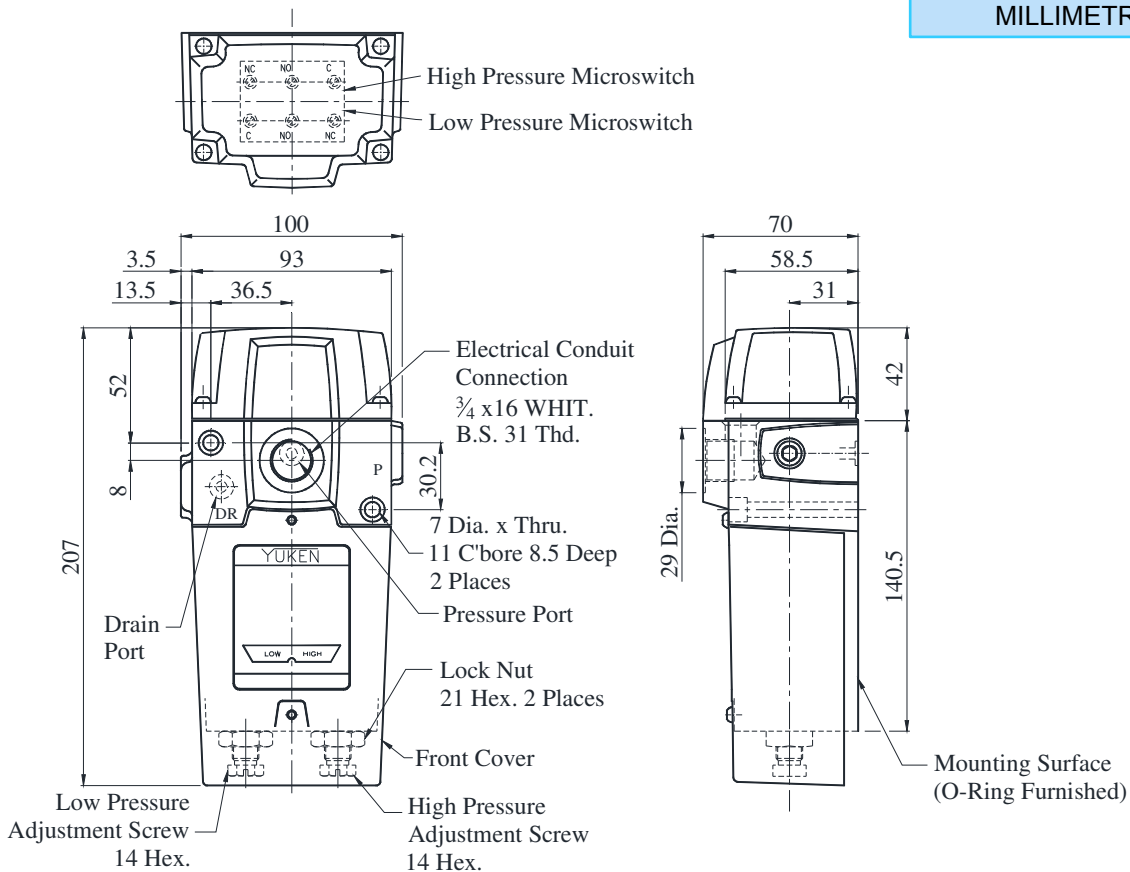

● **Sub-Plate : SGM-02-2080**

DIMENSIONS IN MILLIMETRES

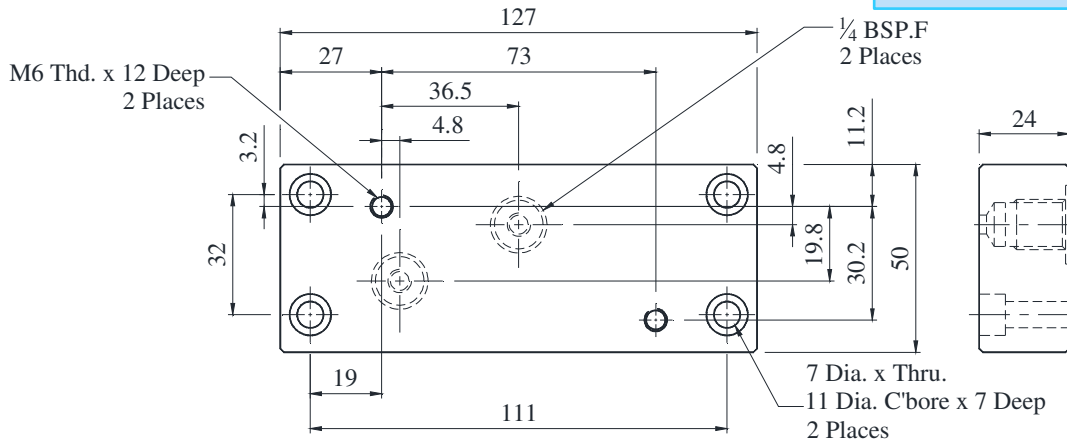

Differential Pressure Characteristic

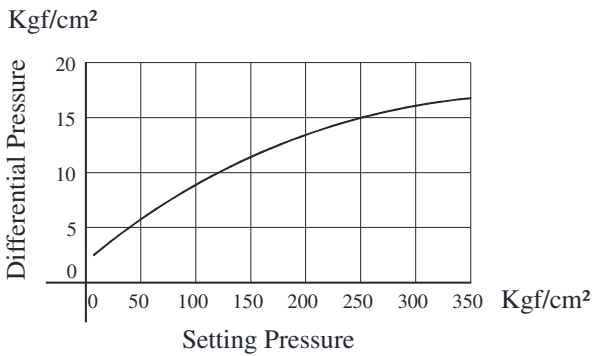

* The differential pressure means the pressure difference caused between at NC and at NO when one of the pressure on the high and low-pressure side is raised and then lowered.

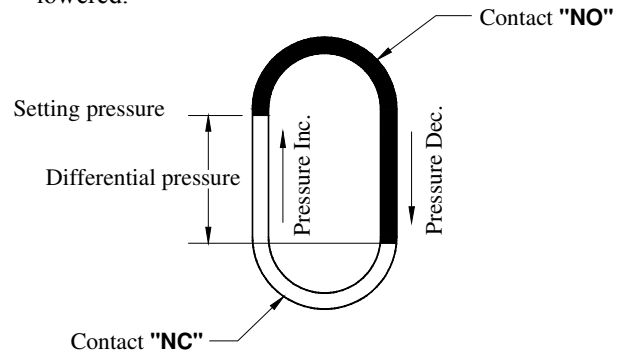

Model Number Designation

Example 1 Solenoid is required to be energized at low pressure and De-energized at high pressure setting.		Example 2 Solenoid is required to be De-energized at low pressure and energized at high pressure setting.		Example 3 Electric motor is required to be started at low Pressure and stopped at high pressure setting.	
Schematic Diagram	Wiring Diagram	Schematic Diagram	Wiring Diagram	Schematic Diagram	Wiring Diagram

Spare Parts List

● **List of Seals**

Sl. No.	Name of Parts	Part Number	Quantity
1	O-Ring	SO-NA-P5	2
2	O-Ring	SO-NB-P8	2
3	Insulation cloth	V*4-0795-0	2
4	Gasket	V*4-0792-0	1

Note : When Ordering the seals, please specify the seal kit number KS-SG-02-2080.

Pressure Switches