

■ Proportional Electro-Hydraulic Pilot Relief Valves

This valve consists of a small DC solenoid and a direct-acting relief valve. It serves as a pilot valve for a low flow rate hydraulic system or a proportional electro-hydraulic control valve and controls the pressure in proportion to the input current. Note that this valve is used in conjunction with the applicable power amplifier.

■ Specification

Model Number		EDG-01
Description		EDG-01
Max. Operating Pres. Kg/cm ²		250
Max. Flow L/min.		2
Min. Flow L/min.		0.3
Pres. Adj. Range Kg/cm ²		Refer to Model No. Designation
Rated Current	mA	EDG-01※-B: 800
		EDG-01※-C: 900
		EDG-01※-H: 950
Coil resistance	Ω	10
Hysteresis		Less than 3%
Repeatability		Less than 1%
Mass (Approx.)	Kg	2

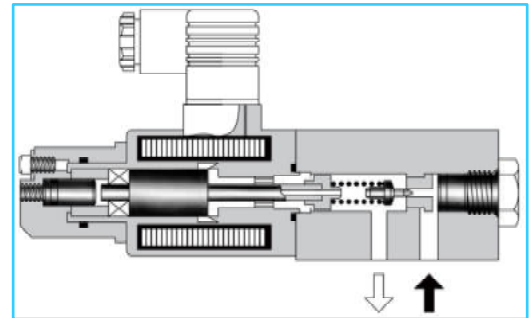
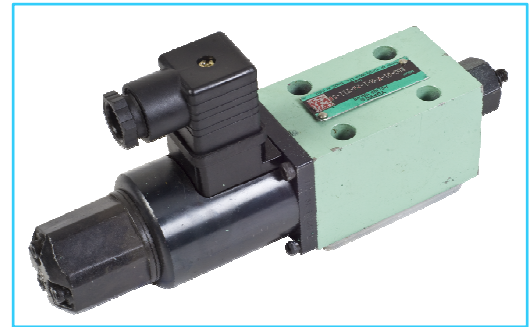

Graphic Symbols

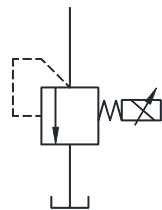

Without Safety Valve

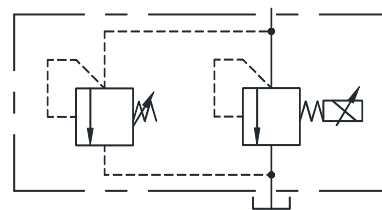

With Safety Valve

■ Model Number Designation

ED	G	-01	V	-C	-1	-PN	T13	-50
Series Number	Type of Mounting	Valve Size	Applicable Control ¹	Pressure Adj. Range Kg/cm ²	Safety Valve	P-Line Orifice	T-Line Orifice ²	Design Number
ED: Proportional Electro-Hydraulic Pilot Relief Valve	G: Sub-Plate Mounting	01	None: General Use V: Vent Control of Relief Valve (Omit if not required)	B: 5 – 70	None: Without Safety Valve 1: With Safety Valve	PN: Without Orifice (Standard)	T15	50
				C: 10 – 160			T13	
				H: 12 – 250			T11	

*1 When the valve is to be used for vent control purpose, orifice adjustment is required due to piping capacity limitations. Therefore, consult Yuken representative in advance.

*2 The orifice used as the pilot valve may differ from the standard orifice.

■ Mounting Bolts

Four Socket head cap screws in the below table are included.

Valve Model Number	Socket head cap Screw	Qty	Bolt Kit Model Number
EDG-01	M5 x 45Lg.	4	BKDSG-01-50

■ Sub-Plate

Piping size	Sub-Plate Model Numbers	Thread size	Mass Kg.
1/8	DSGM-01-3080	1/8 BSP.F	0.8
1/4	DSGM-01X-3080	1/4 BSP.F	0.8

- Sub-plates are available. Specify sub-plate model number from the table above. When sub-plates are not used, the mounting surface should have a good machined finish.

■ Instructions

- **Tank-Line Back Pressure**
Check that the tank line back pressure does not exceed 2 Kgf/cm².
- **Vent control**
When this valve is to be used as a relief valve or for other valve vent control purposes, use 6mm ID, 300mm or less long pipes for piping connections. If pressure instability is encountered, provide a 1-1.5mm diameter orifice for the relief or other valve vent port.
- **Circuit Pressure Control**
When circuit pressure is directly controlled by this valve, make sure that the trapped oil volume is exceeding 40 cm³.

■ Applicable Power Amplifier

For stable performance, it is recommended that Yuken's applicable power amplifiers be used Model Number:

- **PW100-※-H11 (YIL make) Refer EIC-H-1008**
- **AME-D-10-※-20**
- **AME-D2-1010-11**
- **SK1022-※-※-11**
- **SK1015-11 (For DC power supply)**
- **AMN-D-10 (For DC power supply)**

- **Safety Valve Pressure Setting**

The safety valve pressure setting at the maximum flow rate is present to a level that is 20 Kgf/cm² higher than the pressure adjustment range upper limit.

If the operating pressure upper limit is low or a different flow rate upper limit is used, make adjustment after calculating the safety valve pressure setting from the following equation:
Pressure setting=(Operating pressure upper limit) + (Additional pressure indicated below).

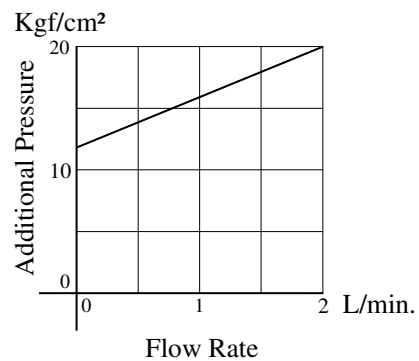

To lower the setting pressure, turn the safety valve pressure adjustment screw anti-clockwise. After adjustment, be sure to tighten the lock nut.

● EDG-01*-*-1-P*T*-50
With safety Valve

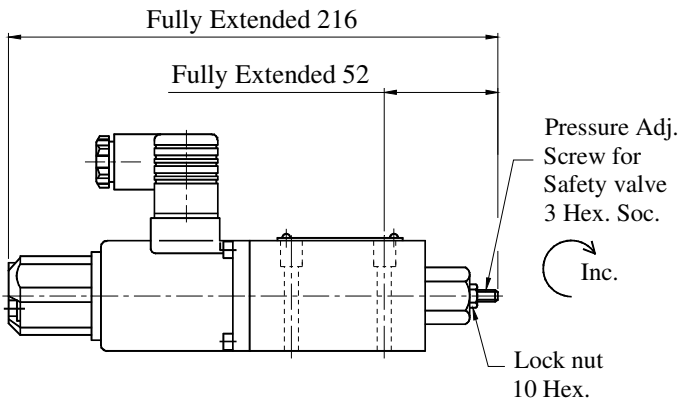

For other dimensions refer without safety valve.

DIMENSIONS IN MILLIMETRES

● EDG-01*-*-P*T*-50
Without safety Valve

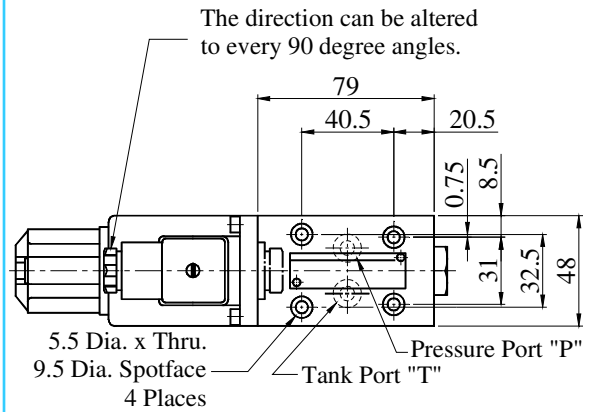

Connector
(The direction can be altered to every 90 degree angles.)

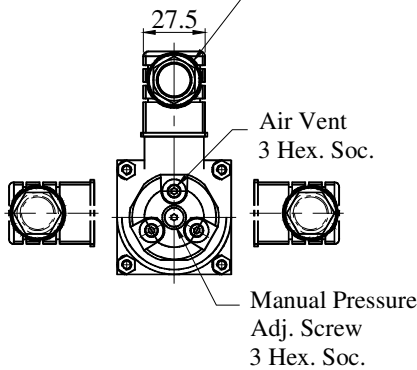

Cable Departure
Cable Applicable : Outside Dia. 8-10 mm
Conductor Area : Not exceeding 1.5 mm²

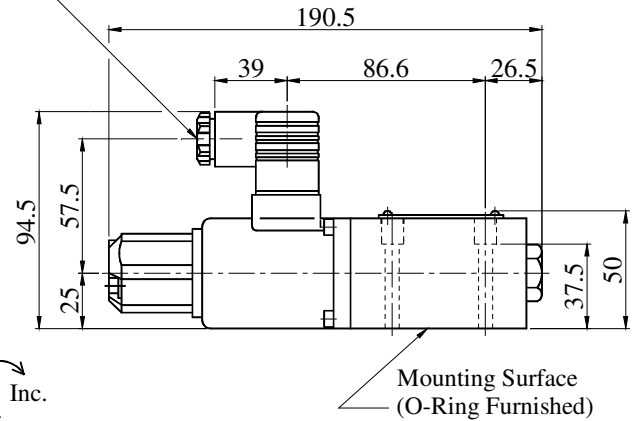

Note :

For valve mounting surface dimensions, see the dimensional drawings of sub-plates in Doc. No. EIC-E-1001 Page No. 358.

■ Spare Parts List

● List of Seals

Sl. No.	Name of Parts	Part No.	Qty.	
			Without Safety Valve	With Safety Valve
1	O-Ring	SO-NB-P9	2	
2	O-Ring	SO-NB-A013	1	
3	O-Ring	SO-NA-P6	-	1
4	O-Ring	SO-NB-P14	1	

● List of Seal Kits

Model Numbers	Seal Kit Numbers
EDG-01-50	KS-EDG-01-50
EDG-01-1-50	KS-EDG-01-1-50

Note : When ordering the seals, please specify the seal kit number from the table above.

● Solenoid Assy.

Valve Model Numbers	Solenoid Assy.
EDG-01*-*-P*T*-50	E318-Y06M2-05-61

Step Response (Example)

These values were measured on independent valves.
They vary by circuit.

Flow Rate : 2 L/min.
Trapped oil volume : 40 cm²
Viscosity : 30 cSt

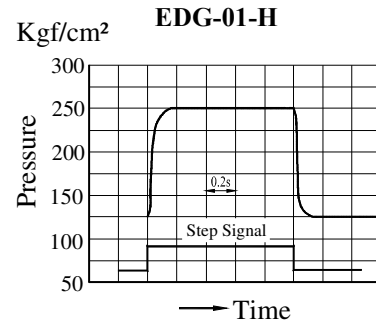
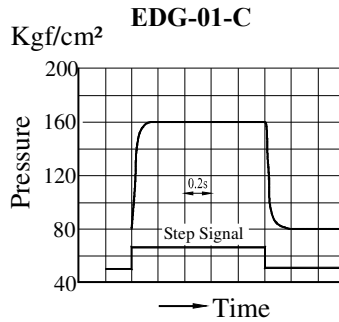
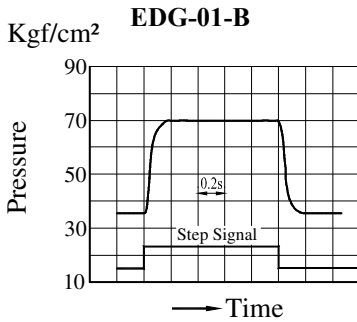

Frequency Response

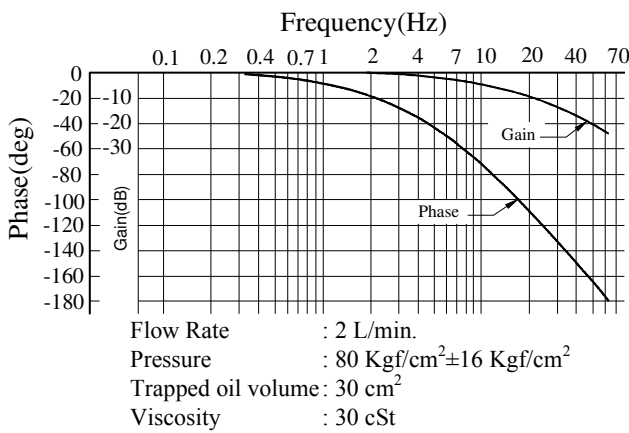

Control Pressure vs. Input Current

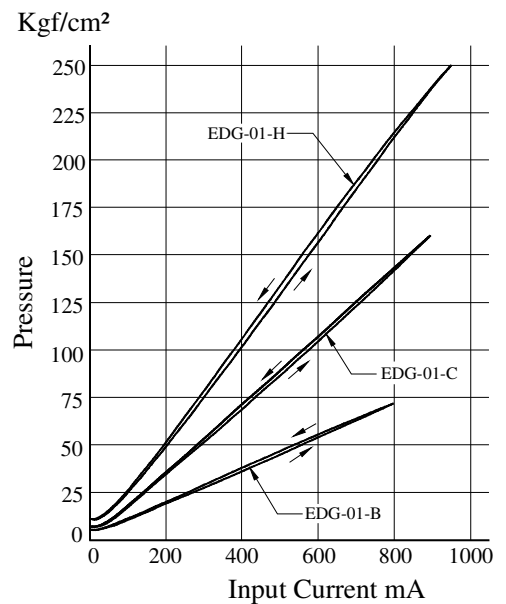

Min. Adjustment Pressure

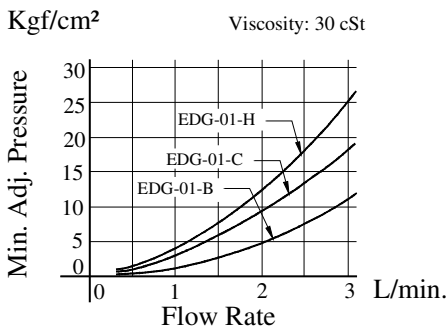

Flow Rate vs. Pressure

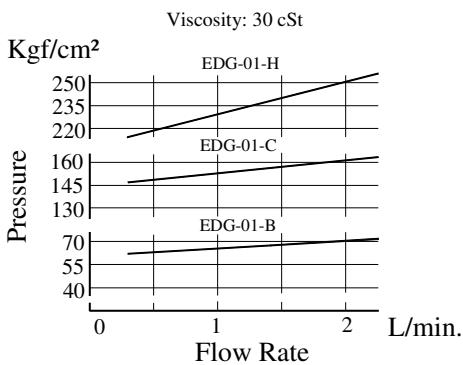

Viscosity vs. Pressure

