

Throttle and Check Valve

This valve is used to regulate an actuator speed in a circuit where line pressure is almost steady and small fluctuation of oil flow due to pressure changes is permitted. Integrated check valve allows reversed free flow from outlet to inlet port.

Graphic Symbol

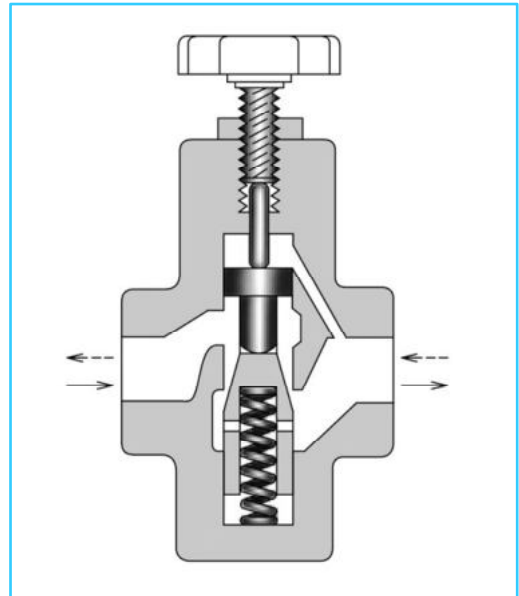
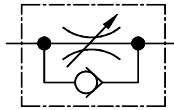

Specifications

Model Numbers		Rated Flow L/min.	Max. Operating Pressure Kgf/cm ²	Mass Kg.
Threaded Connection	SRCT-03-※-4180	30	210	1.2
	SRCT-06-※-4180	85	210	3.2
Sub-Plate Mounting	SRCG-06-※-41	85	210	4.0

Rated flow stands for approximate flow rate when the pressure drop between inlet and outlet ports of the valve is fully opened condition becomes 3Kgf/cm² maximum at fluid's specific gravity of 0.85 and kinematic viscosity of 20 cSt (100SSU)

Model Number Designation

F	SRC	T	-03	-H	-41	※
Special Seals	Serial Number	Type of Mounting	Valve Size	Pr. Differential Kgf/cm ²	Design Number	Design Standard
F: For Phosphate Ester Type Fluids. (Omit if not required)	SRC: Throttle And Check Valve	T: Threaded Connection	03	H: High Pr. Differential 50 ~ 210 L: Low Pr. Differential 5 ~ 50	41	80
			06			----
		G: Sub-Plate Mounting	06			

Also available with Hand knob type on request.

Sub-plate

Valve Model Number	Sub-Plate Model Number	Thread Size	Mass Kg.
SRCG-06	SRGM-06-4080	3/4 BSP.F	2.4
	SRGM-06X-4080	1 BSP.F	3.0

- Sub-plate are available, Specify sub-plate model from the table above. When sub-plates are not used, the mounting surface should have a good machined finish.

Attachment

• **Mounting Bolts**

Valve Model Number	Socket Head Cap Screw	Qty	Bolt Kit Model Number
SRCG-06	M10 x 70 Lg.	4	BKSRG-06-40

● SRCT-03-※-4180
06

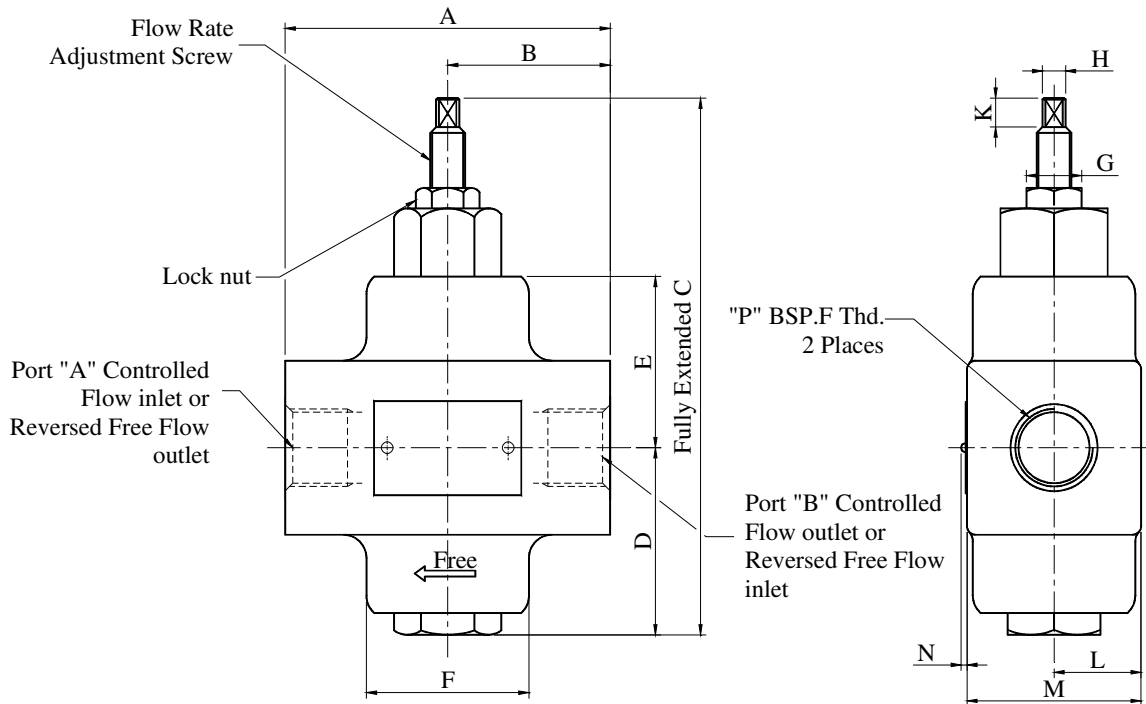

Model No.	A	B	C	D	E	F	G	H	K	L	M	N	P
SRCT-03-※-4180	82	41	151	58	54	40 Dia.	19	Sq. 8	10	20	40	2	3/8 BSP.F
SRCT-06-※-4180	112	56	186	66	59	56 Dia.	19	Sq. 8	10	30	60	2	3/4 BSP.F

DIMENSIONS IN MILLIMETRES

● SRCG-06-※-41

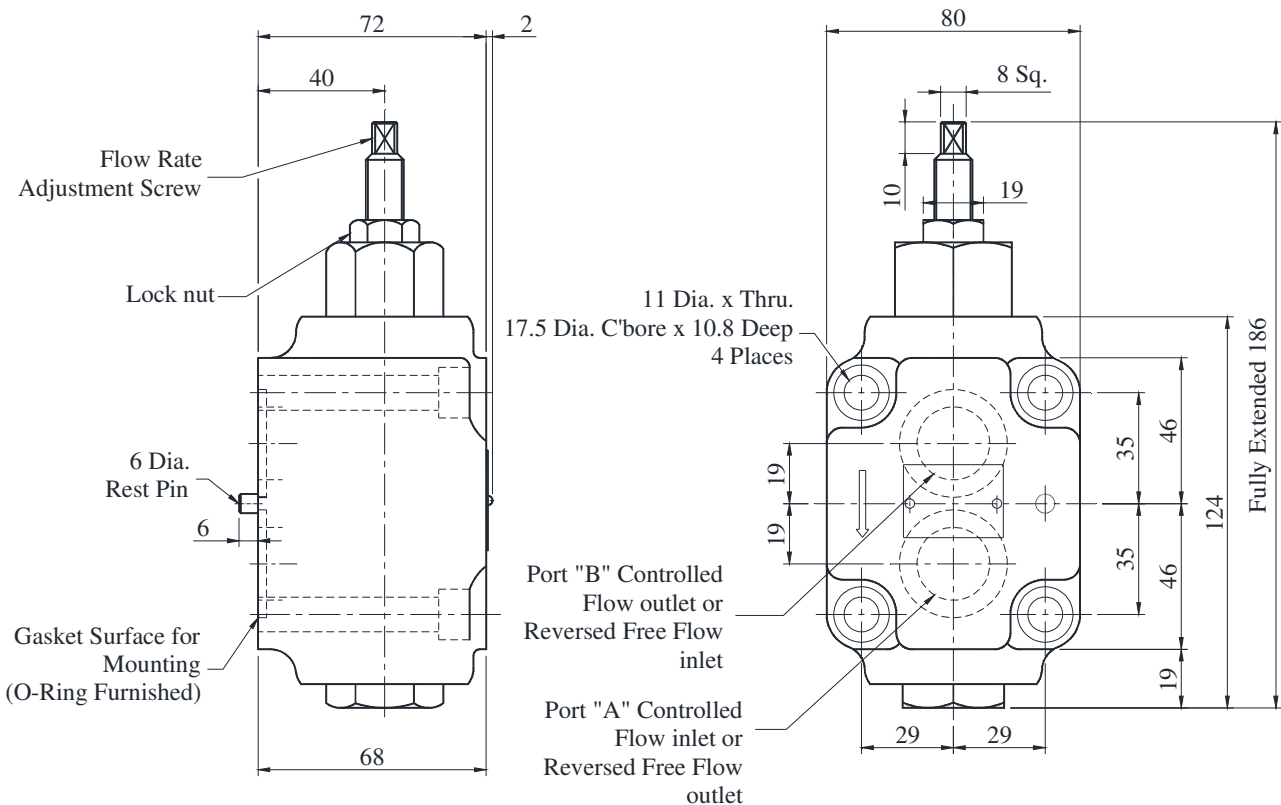

Mounting Sub-Plate

● **SRGM-06-~~※~~-4080**

DIMENSIONS IN MILLIMETRES

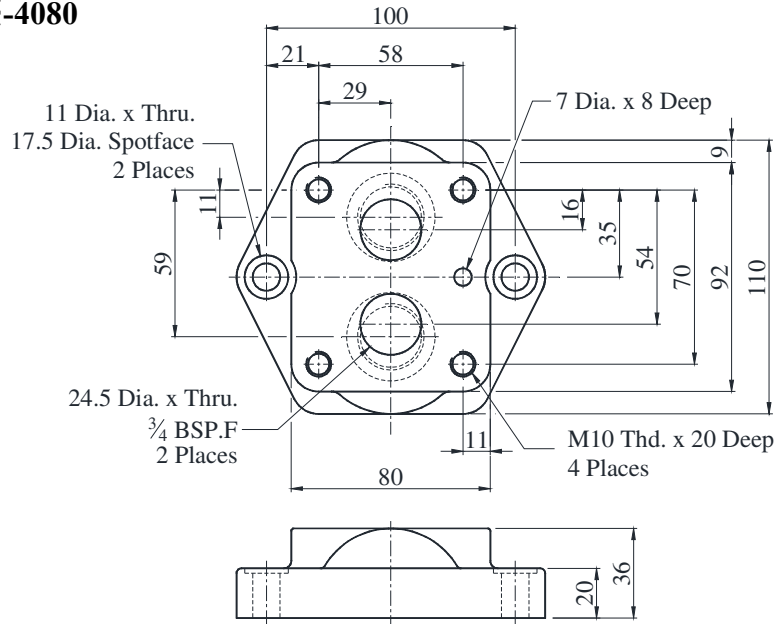

Metered Flow Vs. Adjustment Revolutions

SRCT-03-H-4180

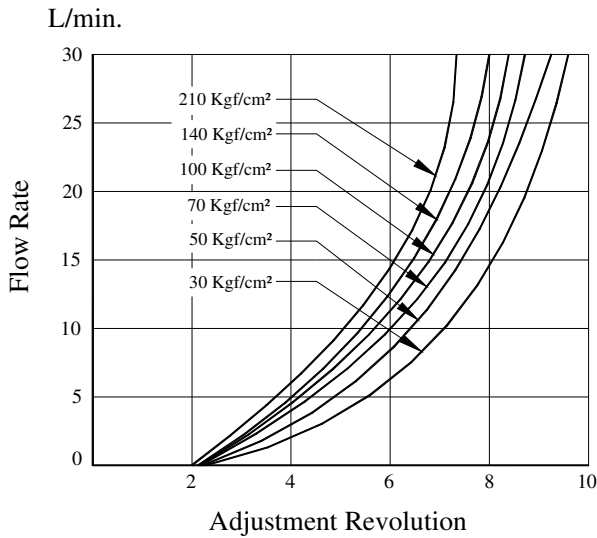

SRCG/SRCT-06-H-41/4180

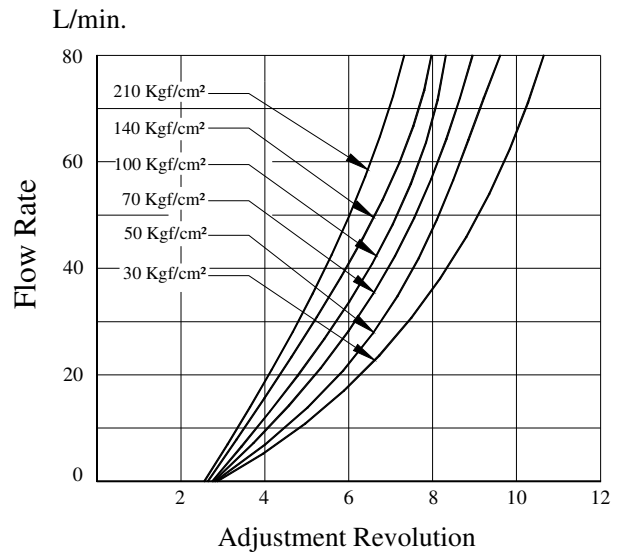

SRCT-03-L-4180

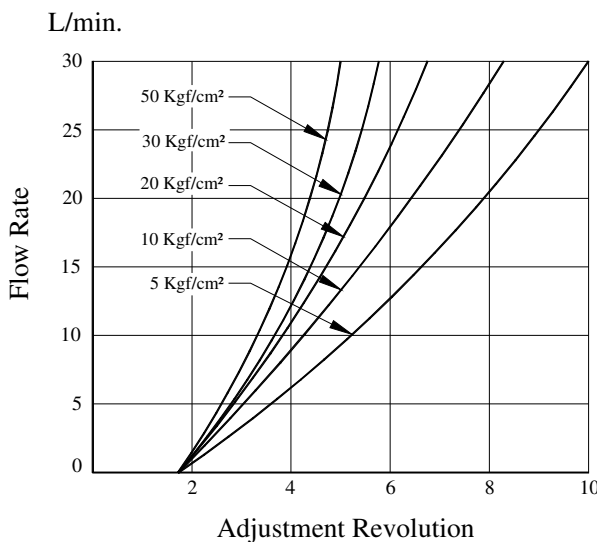

SRCG/SRCT-06-L-41/4180

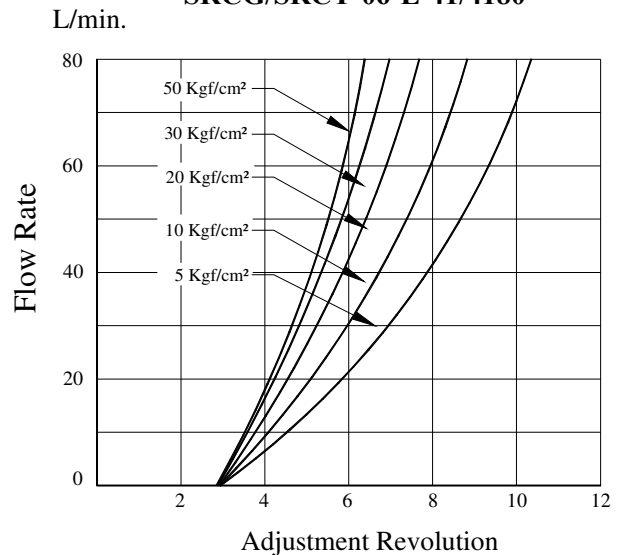

● **Pressure Drop for Reverse Free Flow**

SRCT-03-※-41/4180

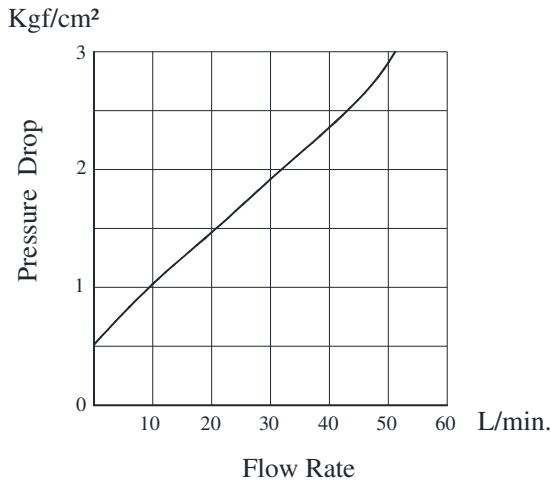

SRCG/SRCT-06-※-41/4180

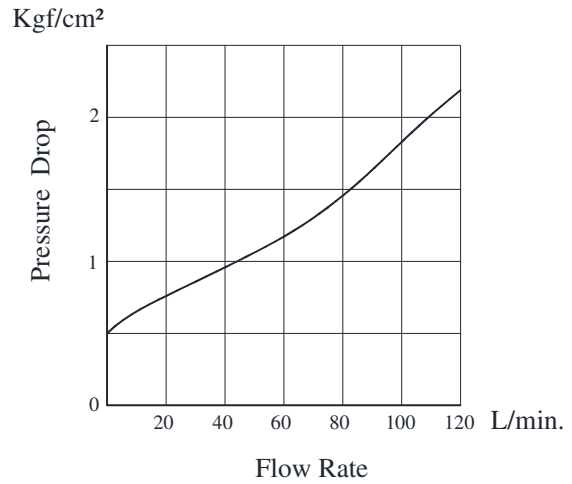

■ **Spare Parts List**

● **List of Seals**

Sl. No.	Name of Parts	Part Numbers					
		SRCT-03	Qty	SRCT-06	Qty	SRCG-06	Qty
1	O-Ring	SO-NA-P12	1	SO-NA-P14	1	SO-NA-P14	1
2	O-Ring	SO-NB-P18	1	SO-NB-P24	2	SO-NB-P24	2
3	O-Ring	-	-	-	-	SO-NB-P28	2
4	Back up Ring	SO-BB-P12	1	SO-BB-P14	1	SO-BB-P14	1

Note : When ordering the seals, please specify the seal kit number from the table below.

● **List of Seals Kits**

Model Numbers	Seal Kit Numbers
SRCT-03	KS-SRCT-03-4180
SRCT-06	KS-SRCT-06-4180
SRCG-06	KS-SRCG-06-41